



**AIR COOLED WATER CHILLERS AND HEAT PUMPS WITH
AXIAL FANS AND SCREW COMPRESSORS**

LVK

SERIES



TECHNICAL MANUAL

INDEX

Declaration of conformity	page 2
Aim and contents of this manual	page 6
How to keep this manual	page 6
Graphic symbols	page 6
Safety laws	page 7
General safety guidelines	page 7
Workers' health and safety	page 8
Protective equipment	page 8
Safety signs	page 8
Technical characteristics	page 9
Technical data	page 12
LVK cooling capacity and compressors input power	page 14
LVK/HP heating capacity and compressors input power	page 15
Evaporator pressure drops	page 16
LVK/A1 – A2 Water pumps available static pressure	page 17
Free Cooling Capacity	page 18
Partial heat recovery capacity	page 19
Operation limits	page 20
Corrections tables	page 20
Sound Data	page 21
Safety Device Setting	page 22
Electric data	page 22
Inspection	page 22
Lifting and handling	page 22
Location and minimum technical clearances	page 23
Hydraulic connections	page 24
LVK/FC Free cooling version	page 26
Remote control panel	page 27
Fan speed control	page 27
Electrical connections	page 27
Start up	page 28
Maintenance and periodic checks	page 29
Refrigerant circuit repair	page 29
Environment protection	page 29
Unit out of service	page 29
Dimensions	page 29

The LVK manual, contains any information that is needed for a correct use of the equipment while safeguarding operator safety, according to what indicated from "Council Directive" 98/37/CE and following changes.

AIM AND CONTENTS OF THIS MANUAL

This manual provides basic information on the installation, operation and maintenance off the LVK unit. It is addressed to machine operators and it enables them to use the equipment efficiently, even if they do not have any previous specific knowledge of it.

This manual describes the characteristics of the equipment at the time it is being put on the market; therefore it may not capture later technological improvements introduced by Ferrolì Spa as part of its constant endeavour to enhance the performance, ergonomics, safety and functionality of its products.

HOW TO KEEP THIS MANUAL

The manual must be always with the unit it refers to. It must be stored in a safe place, away from the dust and moisture. It must be accessible to all users who shall consult it any time they are in doubt on how to operate the equipment.

Ferrolì Spa reserves the right to modify its products and related manuals without necessarily updating previous versions of the reference material. The customer shall store any updated copy of the manual or parts of it delivered by the manufacturer as an attachment to this manual.

Ferrolì spa is available to give any detailed information about this manual and to give information regarding the use and the maintenance of its own units.

GRAPHIC SYMBOLS



Indicates operations that can be dangerous for people and/or disrupts the correct operation of the equipment..



Indicates prohibited operations.



Indicates important information that the operator must follow in order to guarantee the correct operation of the equipment in complete safety

SAFETY LAWS

Ferrol Spa's equipment and their component parts have been designed in compliance with the harmonised EC norms in force and other European and national norms as required by the Council Directive (98/37 and later amendments).

The equipment is also compliant with:

- Norms EN 292-1 e 292-2
- Norma EN 294
- Norms EN 378-1, 378-2, 378-3 e 378-4
- Norma EN 418
- Norma EN 953
- Norma EN 1050
- Norma EN 60204-1
- Norma EN 61000-6-2
- Norma EN 61000-6-4
- Community Directives 98/37/CE, 97/23/CE, 93/68/CEE, 89/336/CEE 73/23/CEE

GENERAL SAFETY GUIDELINES

Before beginning to operate on LVK units every user must be perfectly knowledgeable about the functions of the equipment and its controls and must have read and understood the information container in this manual.



It's strictly forbidden to remove and/or tamper with any safety device.



Any routine or non-routine maintenance operation shall be carried out when the equipment has been shut down, disconnected from electric and pneumatic power source and after its pneumatic system has been discharged.



Do not put your hands or insert screwdrivers, spanners or other tools into moving parts of the equipment.



The equipment supervisor and the maintenance man must receive training suitable for the performance of their tasks in safety



Operators must know how to use personal protective devices and must know the accident-prevention guidelines contained in national and international laws and norms.

WORKERS' HEALTH AND SAFETY

The European Community has adopted a number of directives on workplace health and safety, which include directives **89/391/CEE**, **89/686/CEE**, **89/655/CEE**, **86/188/CEE** and **77/576/CEE**. Every employer shall implement such provisions and ensure that workers respect them:



Do not tamper with or replace parts of the equipment without the specific consent of the manufacturer. The manufacturer shall have no responsibility whatsoever in case of unauthorised operations.



Using components, expendable materials or spare parts that do not correspond to those recommended by the manufacturer and/or listed in this manual may be dangerous for the operators and/or damage the equipment



The operator's workplace must be kept clean, tidy and free from objects that may hamper free movements. Appropriate lighting of the work place shall be provided so as to allow the operator to carry out the required operations safely. Poor or too strong lighting can cause risks.



Ensure that work places are always adequately ventilated and that aspirators are working, in good condition and in compliance with the requirements of the laws in force..

PROTECTIVE EQUIPMENT

When operating and maintaining the LVK units, use the following personal protective equipment.



Protective clothing: Maintenance men and operators must wear protective clothing that complies with the basic safety requirements currently in force. In case of slippery floors users must wear safety shoes with non-slip soles.



Gloves: During maintenance or cleaning operation protection gloves must be used



Mask and goggles: Respiratory protection (mask) and eye protection (goggles) should be used during cleaning and maintenance operations.

SAFETY SIGNS

The equipment features the following safety signs, which must be complied with:



General hazard



Electric shock hazard

TECHNICAL CHARACTERISTICS

Frame

All LVK units are made from hot-galvanised thick sheet metal, painted with polyurethane powder enamel at 180°C to ensure the best resistance against the atmospheric agents. The frame is self-supporting with removable panels. All screws and rivets for outdoor installations are in stainless steel. The colour of the units is RAL 7035.

Refrigerant circuit

The refrigerant gas used in these units is R407C. The refrigerant circuit is made by using international primary brands components and according to ISO 97/23 concerning welding procedures. Each refrigerant circuit is totally independent from the other. Any incorrect operation of one circuit does not influence the other circuit. The refrigerant circuit includes:

liquid line manual shut-off valve,

sight glass,

filter drier,

thermal expansion valve with external equalizer,

electric expansion valve with electronic control to optimize the efficiency in part load conditions (option),

reverse cycle valve (for heat pump version only),

one way valve (for heat pump version only),

liquid receiver (for heat pump version only),

Schrader valves for maintenance and control,

pressure safety device (according to PED regulation).

Compressors

The compressors are screw type, Star-Delta starting, double rotor with crankcase heater and thermal overload protection by a klixon embedded in the motor winding. They are mounted in a separate chamber in order to be separated from the air stream. The crankcase heater is always powered when the compressors are in stand-by. Each compressor is standard equipped with 3 capacity steps. The inspection is possible through the frontal panel of the unit that allows the maintenance of the compressors even if the unit is working.

Condensers

The condensers are made of copper pipes and aluminium fins. The diameter of the copper pipes is 3/8" and the thickness of the aluminium fins is 0,1 mm. The tubes are mechanically expanded into the aluminium fins to improve the heat exchange factor. The geometry of these condensers guarantees a low air side pressure drop and then the use of low rotation (and low noise emission) fans. The condensers can be protected by a metallic filter to be installed on request.

Fans

The fans are axial type with aerofoil blades. They are statically and dynamically balanced and supplied complete of the safety fan guard according to EN 60335. They are mounted on the unit frame by interposition of rubber vibration dampers. The electric motors are all at 6 poles (about 900 rpm). The motors are directly driven with an integrated thermal overload protection. The protection class of the motors is IP 54.

Evaporators

From size 1601 to 4502 they are made of AISI 316 stainless steel braze-welded plates type; from size 5202 to 9002 are shell in tube type. Each evaporator is factory insulated with flexible close cell material and can be equipped with antifreeze heater (optional). Each evaporator is provided standard with a temperature sensor as antifreeze protection.

Hydraulic circuit (A versions only)

The LVK chillers can be delivered as option, with a built in hydraulic kit that includes:

Water tank in different sizes (depending on the size of the unit), factory insulated with flexible close cell material and prepared for the installation of antifreeze kit (option). The water tank is installed to minimize the inevitable fluctuations in the water temperature due to the compressors starts and stops.

Water pump, centrifugal type, is available in single or double configuration. In this case one pump is running, one pump is in stand-by. The change over can be manual (by manual selector installed in the electric box) or automatically controlled by the microprocessor (option).

In the hydraulic circuit are also present the expansion vessel, the safety valve and the manual valves with fittings.

Electric enclosure

The electric switch board is made according to electromagnetic compatibility norms CEE 73/23 and 89/336. The accessibility to the board is possible after removing the front panel of the unit and the OFF positioning of the main switch. The moisture protection degree is IP55. In all LVK units are installed, standard, the compressors sequence relay who disables the operation of the compressor in case the power supply phase sequence is not the correct one. The following components are also standard installed: main switch, magnetic-thermal switches (as a protection of compressors, pumps and fans), control circuit automatic breakers, compressor contactors, fan contactors, pump contactors. The terminal board is supplied with voltage free contacts for remote ON-OFF, Summer / winter change over (heat pumps only) and general alarm.

Microprocessors

All LVK units are supplied standard with microprocessor controls. The microprocessor controls the following functions: regulation of the water temperature, antifreeze protection, compressor timing, compressor automatic starting sequence, alarm reset, potential free contact for remote general alarm, alarms and operation leds. Upon request any microprocessor can be connected to a BMS system for the remote control and management. The technical department is available to study, together with the customer, different solutions using MODBUS; LONWORKS; BACNET or TREND protocols.

Control and protection devices

All units are supplied with the following control and protection devices: Return water temperature sensor, installed on the return water line from the plant (12°C), antifreeze protection sensor installed on the outlet water temperature (7°C), high pressure switch with manual reset, low pressure switch with automatic reset, high pressure safety valve, compressor thermal overload protection, fans thermal overload protection, flow switch.

OTHER VERSIONS

Low noise version (LS)

The low noise version is especially designed to be installed in applications where the sound level is the most important key. The units are built with a complete insulation of the compressor vane with high density sound absorption material.

Heat pumps version (HP)

The heat pump versions are provided with a 4 way reverse cycle valve and are suitable to produce hot water up to a temperature of 45-50°C. They are always supplied with liquid receiver and a second thermostatic valve to optimize the efficiency of the refrigerant cycle in heating and in cooling. The microprocessor is set for automatic defrost (in case of operation in severe ambient conditions) and for summer/winter change over.

Free cooling version (FC)

The FREE COOLING option is a system designed to grant an important energy saving, when the cooling system is operating continuously, also during the winter season (computer rooms, telephone exchange plants, etc.). The free-cooling device is using the low ambient air temperature to cool down the water in the system. In some situations the chilled water can be even produced without the work of the compressors with consequent massive reduction of electric power consumption. The FREE COOLING system is composed by the following components:

- Free cooling coil:** It is essentially a heat exchanger made of copper tubes and aluminium fins with bleeding valves.
- Microprocessor control:** It is the “heart” of the system; it allows the correct control of all the parameters performing the best efficiency of the system in the different ambient conditions.
- 3 way valve:** It is an ON/OFF 3 way valve that opens or closes the FREE COOLING circuit depending on the signal coming from the microprocessor control.
- Head pressure control:** It is a device that allows the correct condensing pressure in the refrigerant circuit when the ambient conditions are low. In the units equipped with FREE COOLING system, this device is composed by solenoid valves that close some refrigerant circuits in the condensing coil in order to reduce its exchange capacity and to keep a suitable condensing pressure level.

**WATER CHILLERS AND HEAT PUMPS
LVK SERIES
TECHNICAL DATA**

Mod.		1601	1901	2301	2701	3201	3601	4001	
Refrigerant		R407C	R407C	R407C	R407C	R407C	R407C	R407C	
Cooling capacity	Kw	158	183	225	270	323	360	410	
Compressors input power	Kw	57,0	65,1	78,4	94,5	111,3	122,5	134,0	
Water flow rate	l/h	24950	31500	38700	46500	55600	61900	70600	
Water pressure drops	Kpa	47	41	43	41	38	28	39	
Heating capacity	Kw	170	191	260	290	345	381	440	
Compressors input power	Kw	54,2	62,7	75,5	92,5	107,2	118,8	131,2	
Water flow rate	l/h	29300	32900	44800	49900	59400	65500	75700	
Water pressure drops	Kpa	64	46	57	47	44	11,5	44,9	
Free cooling capacity	kW	94	110	135	135	185	185	245	
Input power	kW	2,8	6	8	8	12	12	16	
Water flow rate	l/h	24950	31500	38700	46500	55600	61900	70600	
Water pressure drops	Kpa	87	82	115	118	121	131	109	
Total input current	A	95,0	119,0	146,0	168,0	197,0	212,0	244,0	
Total peak current	A	164,0	205,0	270,0	334,0	378,0	398,0	485,0	
Maximum input current	A	129,0	152,0	184,0	212,0	249,0	269,0	302,0	
Power supply	V/Ph/Hz	400/3/50							
Airflow	m3/h	34920	55800	58800	58800	88500	88500	118000	
Fans	n° x kW	4 x 0,69	3 x 2	4 x 2	4 x 2	6 x 2	6 x 2	8 x 2	
Compressor	type	Screw							
	n°	1	1	1	1	1	1	1	
Refrigerant circuit	n°	1	1	1	1	1	1	1	
Step controls	n°	3	3	3	3	3	3	3	
Sound power level basic version ⁽¹⁾	dB(A)	86	88	91	91	93	93	94	
Sound pressure level basic version ⁽²⁾	dB(A)	58	60	63	63	65	65	66	
Sound power level (LS) version ⁽¹⁾	dB(A)	83	85	88	88	90	90	91	
Sound pressure level (LS) version ⁽²⁾	dB(A)	55	57	60	60	62	62	63	
Water pump (option)	Kw	3,0	3,0	4,0	4,0	5,5	7,5	7,5	
Pump available pressure (option)	kPa	190	150	180	148	170	175	154	
Water tank capacity (option)	l	670	670	670	670	670	670	670	
Expansion vessel (option)	l	25	25	25	25	25	25	25	
Lenght	mm	4108	4708	4708	4708	4708	4708	4708	
Width	mm	1105	1105	1105	1105	2200	2200	2200	
Height	mm	2179	2262	2262	2262	2350	2350	2350	
Weight (Standard configuration)	Kg	1850	2090	2290	2680	3100	3200	3350	
Weight (A2 configuration)	Kg	2150	2390	2590	2980	3520	3670	3810	

Performances are referred to the following conditions:

Cooling: ambient air temperature 35 °C; evaporator water temperature in/out 12/7 °C.

Heating: ambient air temperature 8.3 °C DB, 6.1 °C WB ; condenser water temperature in/out 40/45 °C.

Free cooling: ambient air temperature 2°C; water inlet temperature 15°C, glycol 20%, nominal waterflow, compressors switched off.

(1): Sound power level according to ISO 3746.

(2): Sound pressure level measured at 10 mt from the unit in free field conditions direction factor Q=2 according to ISO 3746.

**WATER CHILLERS AND HEAT PUMPS
LVK SERIES
TECHNICAL DATA**

Mod.		3202	3602	4502	5202	6402	7202	8202	9002
Refrigerant		R407C	R407C	R407C	R407C	R407C	R407C	R407C	R407C
Cooling capacity	Kw	318	360	450	520	640	720	820	900
Compressors input power	Kw	113,0	130,2	156,8	189,0	222,6	245,0	268,0	296,4
Water flow rate	l/h	54700	61900	77400	89500	110000	123900	141000	154800
Water pressure drops	Kpa	33	28	36	49	53	67	50	43
Heating capacity	Kw	354	385	483	555	670	745	835	910
Compressors input power	Kw	111	116	149	173	209	235	258	282
Water flow rate	l/h	61000	66300	83100	95500	115300	128200	143700	157000
Water pressure drops	Kpa	47	32	42	54	58	75	53	47
Free cooling capacity	kW	185	245	245	320	380	380	430	490
Input power	kW	12	16	16	20	24	24	28	32
Water flow rate	l/h	54700	61900	77400	89500	110000	123900	141000	154800
Water pressure drops	Kpa	121	131	109	109	103	92	118	124
Total input current	A	204,0	246,0	292,0	344,0	394,0	424,0	480,0	526,0
Total peak current	A	273,0	332,0	416,0	510,0	575,0	610,0	721,0	838,0
Maximum input current	A	272,0	312,0	368,0	440,0	498,0	538,0	596,0	664,0
Power supply	V/Ph/Hz	400/3/50							
Airflow	m3/h	88500	118000	118000	150000	178000	178000	207000	236000
Fans	n° x kW	6 x 2	8 x 2	8 x 2	10 x 2	12 x 2	12 x 2	14 x 2	16 x 2
Compressor	type	Screw							
	n°	2	2	2	2	2	2	2	2
Refrigerant circuit	n°	2	2	2	2	2	2	2	2
Step controls	n°	6	6	6	6	6	6	6	6
Sound power level basic version ⁽¹⁾	dB(A)	93	93	94	94	97	98	99	100
Sound pressure level basic version ⁽²⁾	dB(A)	65	65	66	66	69	70	71	72
Sound power level (LS) version ⁽¹⁾	dB(A)	90	90	91	91	94	95	96	97
Sound pressure level (LS) version ⁽²⁾	dB(A)	62	62	63	63	66	67	68	69
Water pump (option)	Kw	5,5	7,5	7,5	7,5	11	11	15	15
Pump available pressure (option)	kPa	170	175	130	85	205	175	220	195
Water tank capacity (option)	l	670	670	670	670	1000	1000	1000	1000
Expansion vessel (option)	l	25	25	25	25	25	25	25	25
Lenght	mm	4708	5200	5200	6200	7206	7206	9300	9800
Width	mm	2200	2200	2200	2200	2200	2200	2200	2200
Height	mm	2350	2350	2350	2350	2350	2350	2350	2350
Weight (Standard configuration)	Kg	4100	4500	4800	5600	6200	6400	8570	10200
Weight (A2 configuration)	Kg	4770	5240	5590	6510	7200	7440	9970	11800

Performances are referred to the following conditions:

Cooling: ambient air temperature 35 °C; evaporator water temperature in/out 12/7 °C.

Heating: ambient air temperature 8.3 °C DB, 6.1 °C WB ; condenser water temperature in/out 40/45 °C.

Free cooling: ambient air temperature 2°C; water inlet temperature 15°C, glycol 20%, nominal waterflow, compressors switched off.

(1): Sound power level according to ISO 3746.

(2): Sound pressure level measured at 10 mt from the unit in free field conditions direction factor Q=2 according to ISO 3746.

**LVK (COOLING ONLY VERSION)
COOLING CAPACITY AND COMPRESSORS INPUT POWER**

PA = Compressor input power

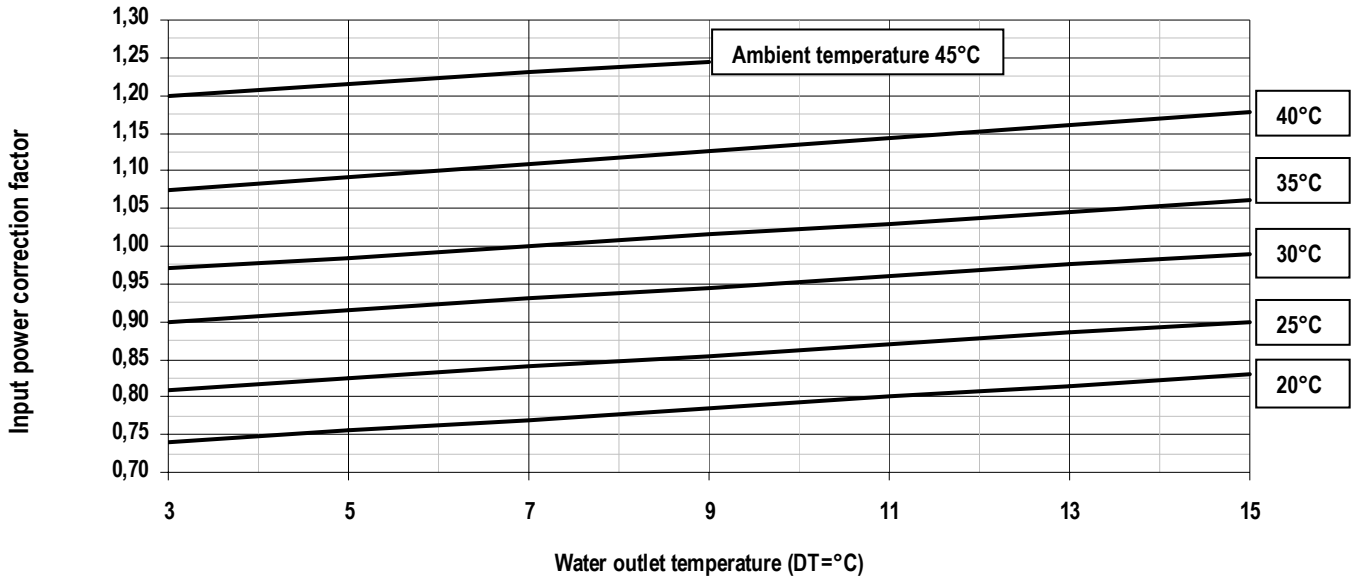

PF = Cooling capacity

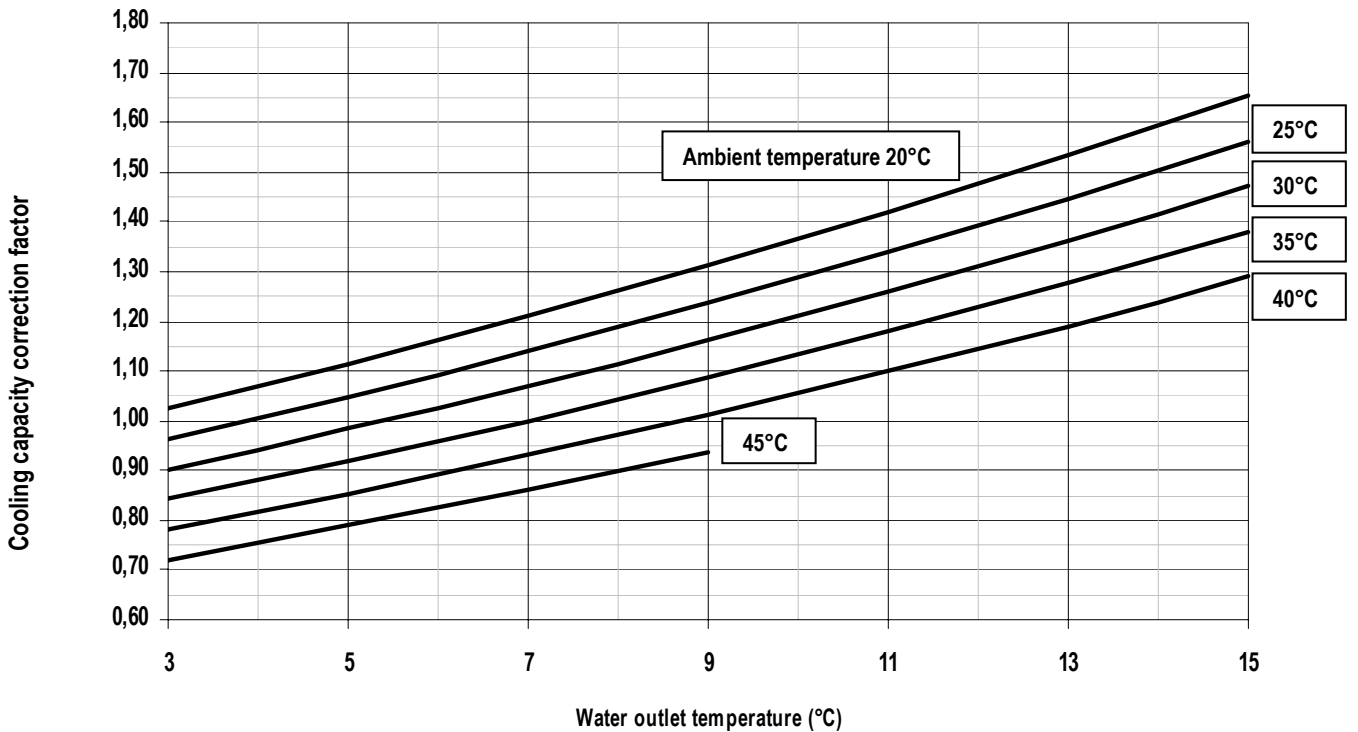

The cooling capacity and the compressors input power in different working conditions can be obtained by multiplying the nominal values (PF, PA) with their respective correction factors. The diagram below indicates the correction factors; for each curve, the relative ambient conditions, assuming that the difference between inlet and outlet cold water temperature is 5°C.

**LVK / HP (HEAT PUMP VERSION)
HEATING CAPACITY AND COMPRESSORS INPUT POWER**

PA = Compressor input power

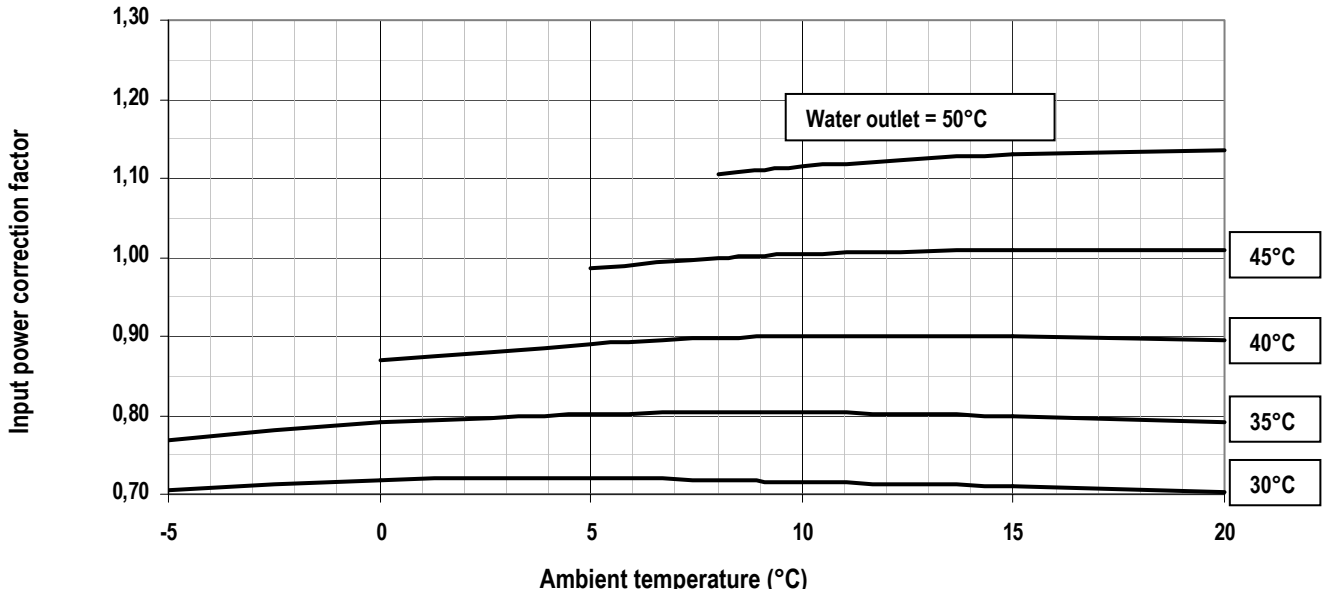

PH = Heating capacity

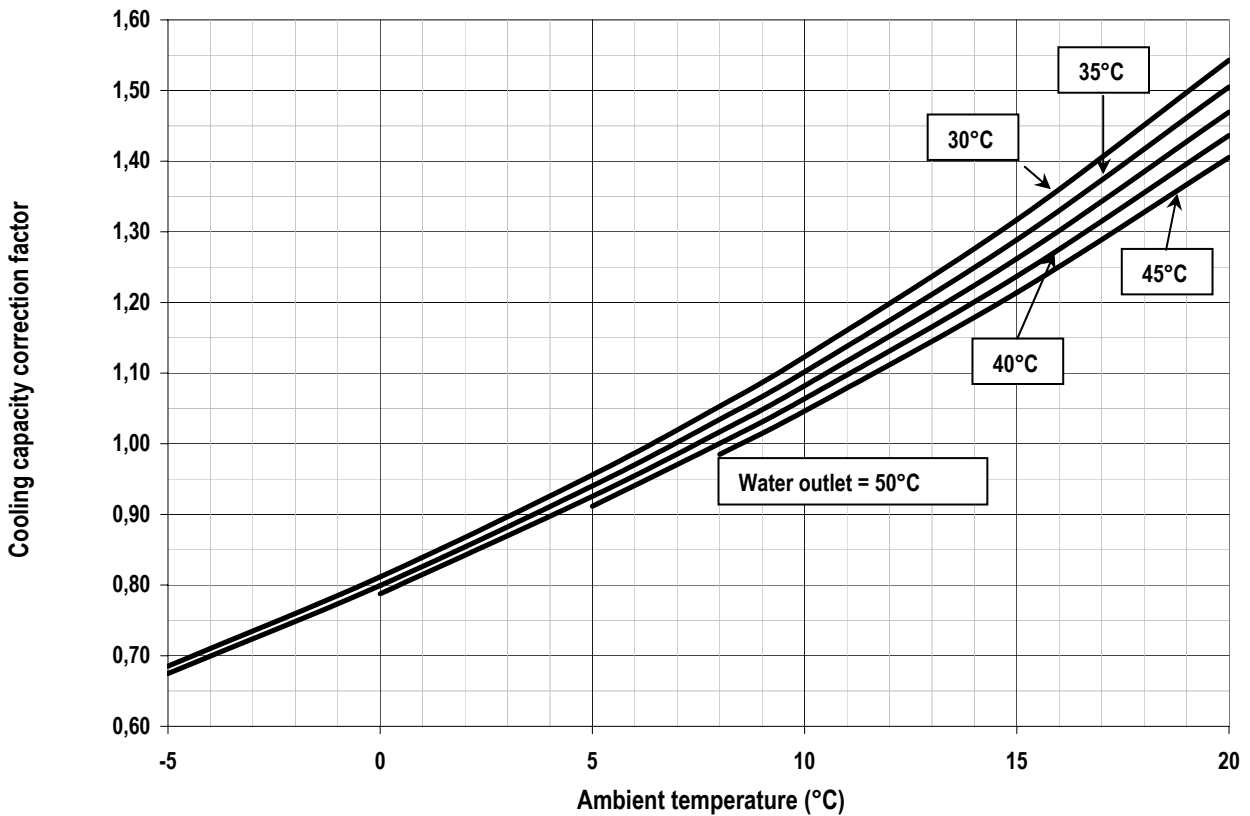

The heating capacity and the compressors input power in different working conditions can be obtained by multiplying the nominal values (PH, PA) with their respective correction factors. The diagram below indicates the correction factors; for each curve, the relative hot water temperature produced is indicated, assuming that the difference between inlet and outlet water temperature is 5°C. Capacities do not include the heating capacity lost due to the defrosting periods.

EVAPORATOR PRESSURE DROPS

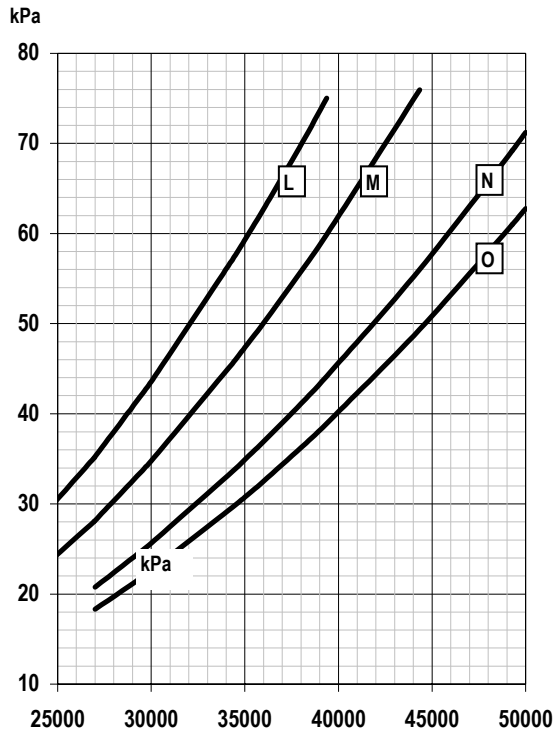

L: LVK1601
N: LVK 2301

M: LVK 1901
O: LVK2701

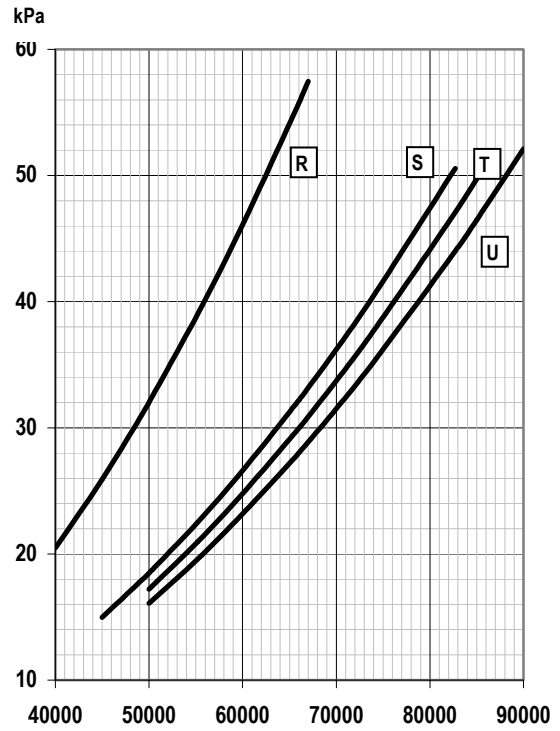

R: LVK3201 / LVK3202
S: LVK3601 / LVK3602
T: LVK4001

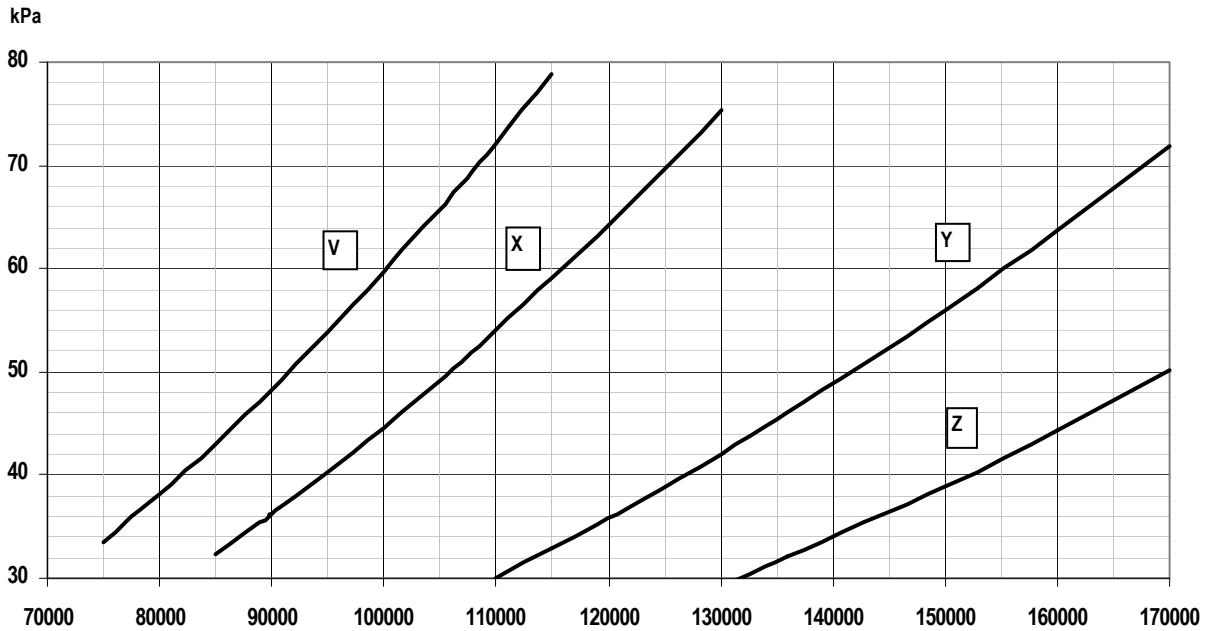

V: LVK4502 / LVK5202
Y: LVK8202

X: LVK6402/ LVK7202
Z: LVK 9002

WATER PUMPS AVAILABLE STATIC PRESSURE

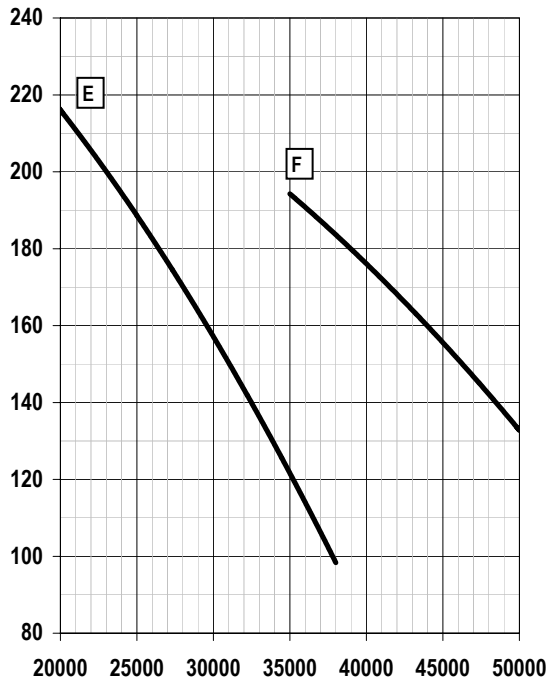

E: LVK1601,1901
F: LVK 2301, 2701

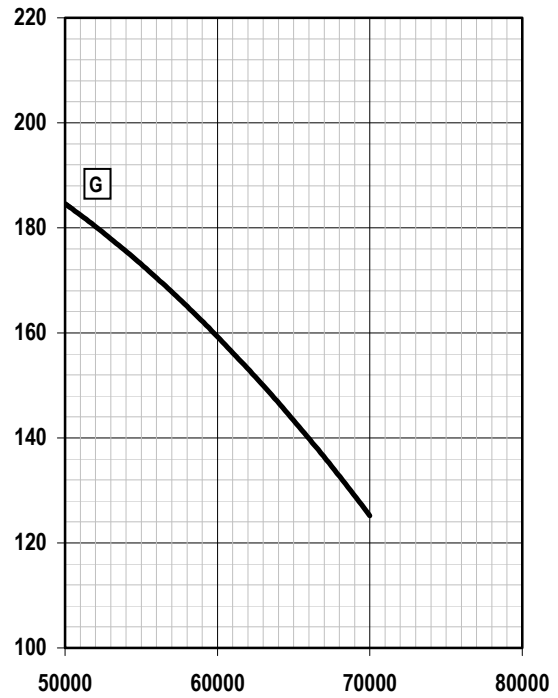

G: LVK3201, 3202

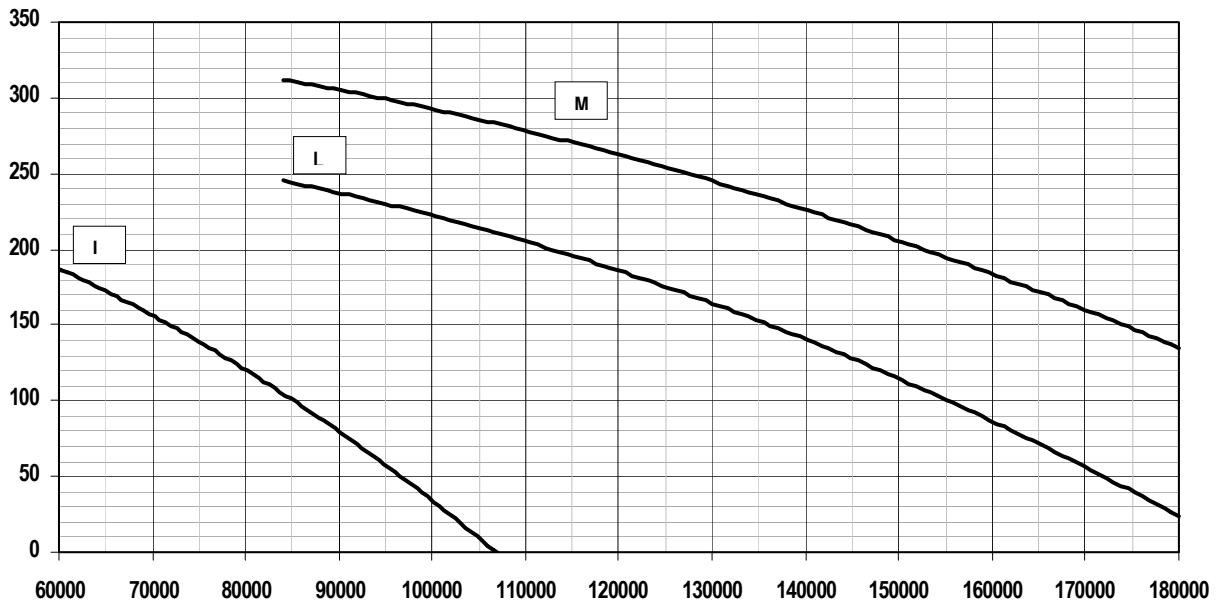

I: LVK 3601 - 3602 - 4001 - 4502 - 5202
L: LVK 6402 - 7202
M: LVK 8202 - 9002

FREE COOLING CAPACITY

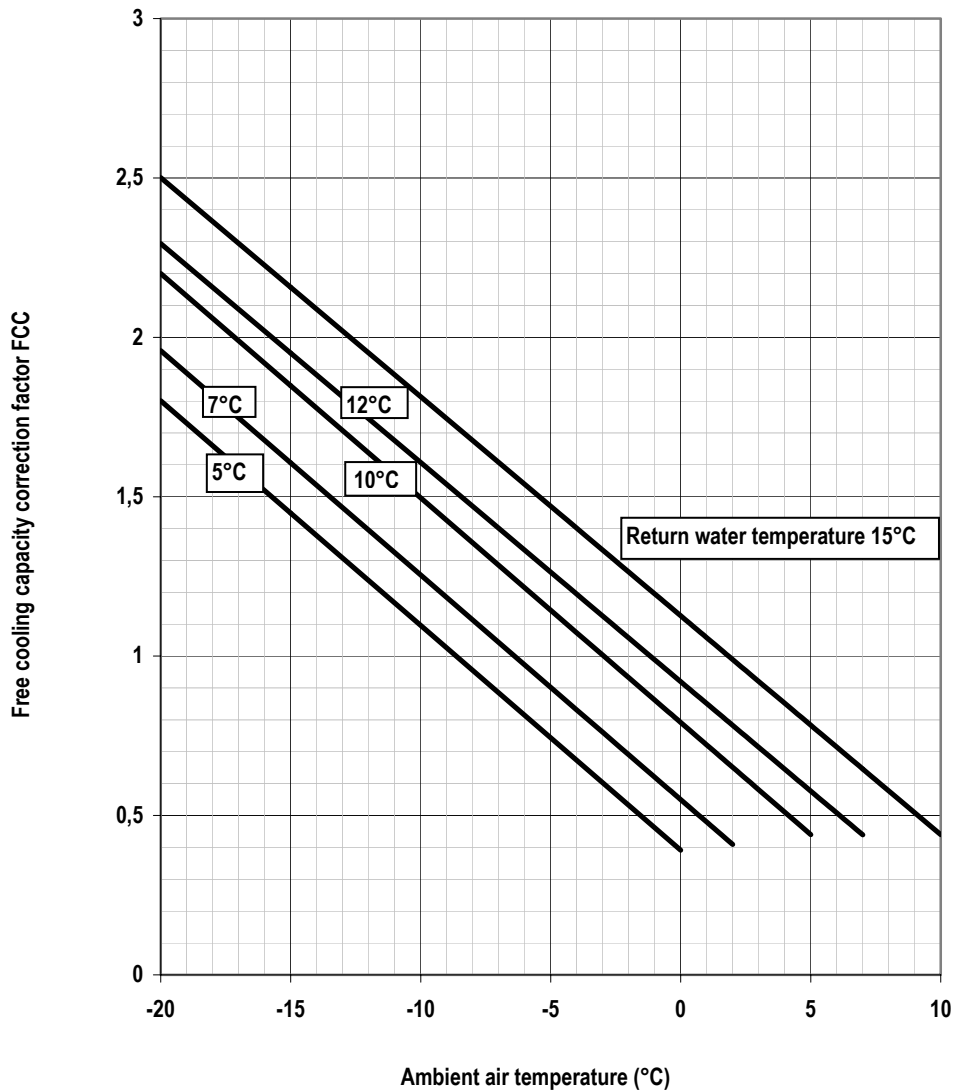

Mod.		1601	1901	2301	2701	3201	3601	4001	
Nominal Free cooling capacity	kW	94	110	135	135	185	185	245	
Mod.		3202	3602	4502	5202	6402	7202	8202	9002
Nominal Free cooling capacity	kW	185	245	245	320	380	380	430	490

The nominal Free Cooling capacity is obtained when all compressors are OFF, the return water temperature from the system is 15°C and the ambient temperature is 2°C. To calculate the free cooling capacity in different conditions please refer to the above diagram. The FCC factor obtained by the diagram has to be multiplied by the nominal Free cooling capacity reported in the table.

PARTIAL HEAT RECOVERY CAPACITY

Mod.		1601	1901	2301	2701	3201	3601	4001	
Partial heat recovery nominal capacity	kW	43	50	60	73	87	96	110	
Water flow	l/h	7400	8540	10450	12540	14950	16600	18700	
Water pressure drops	kPa	11	16	24	21	24	28	33	
Mod.		3202	3602	4502	5202	6402	7202	8202	9002
Partial heat recovery nominal capacity	kW	87	96	120	140	173	190	215	240
Water flow	l/h	14950	16600	20880	24400	29700	33200	37400	41200
Water pressure drops	kPa	24	28	39	34	39	33	39	32

The nominal value refers to an ambient temperature 35°C and outlet water temperature 50°C (Dt 5°C).

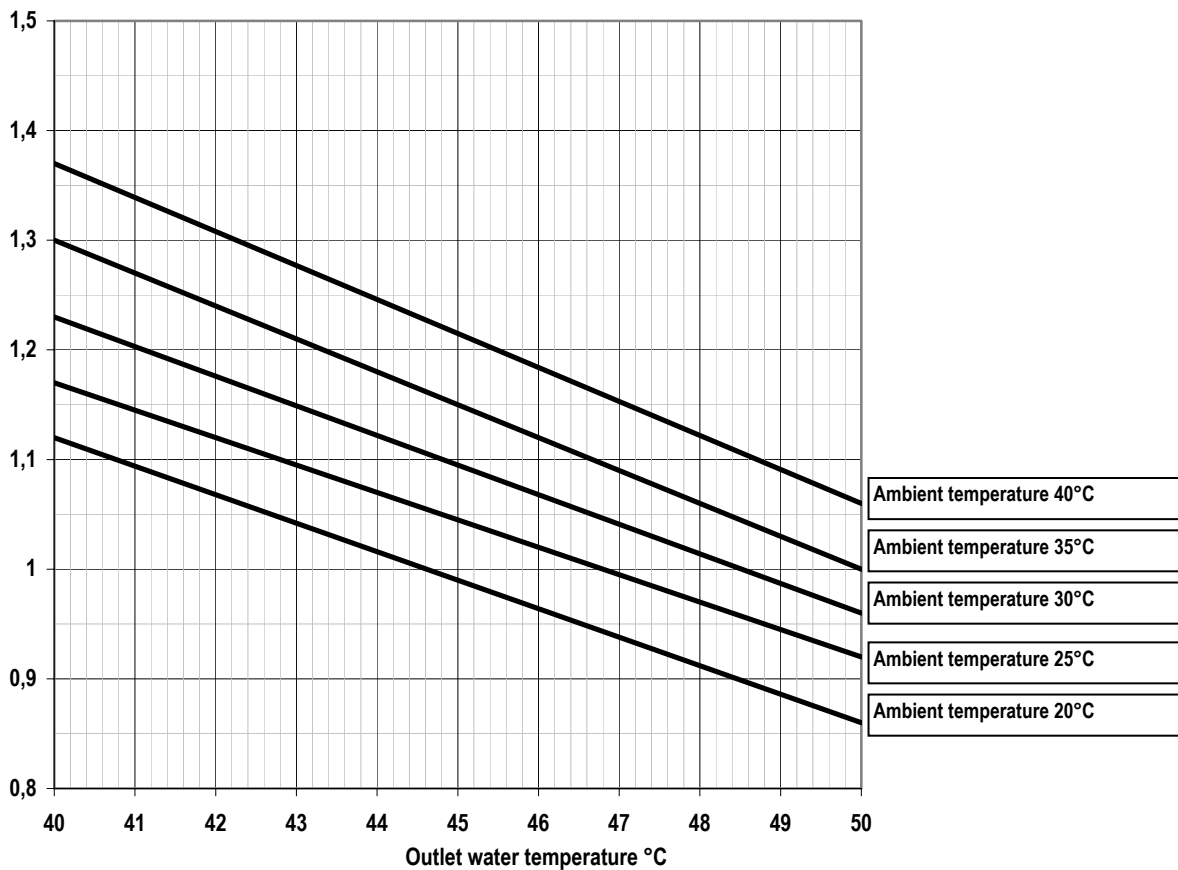

The heat recovery capacity in different conditions can be obtained multiplying the nominal capacity (See above), by the correction factor indicated in the table.



WARNING: the partial heat recovery can only work in cooling mode; in case of heat pump version it is necessary to intercepted the heat recovery in heating mode, otherwise the unit can be damaged. The guarantee will not be valid in case the heat recovery is not intercepted.

OPERATION LIMITS

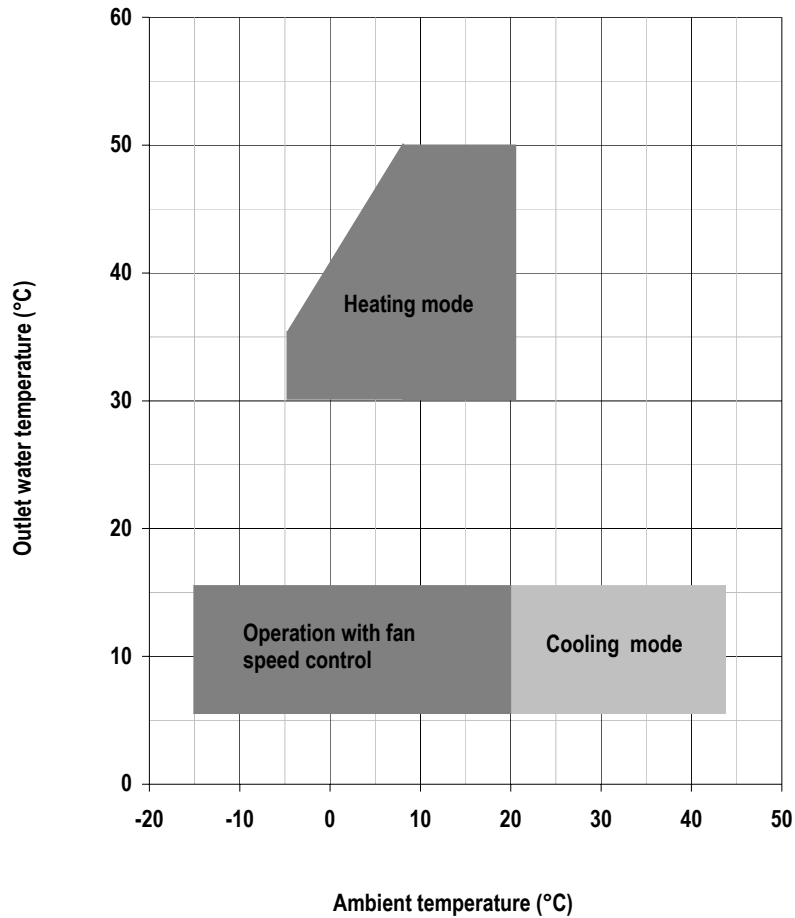

Evaporator water flow rate

The nominal water flow rate given by Ferrol is referred to a Dt of 5 °C. Maximum flow rate allowed is the one that presents a Dt of 3 °C: higher values may cause too high pressure drop. The minimum water flow rate allowed is the one presenting a Dt of 8 °C. Insufficient values cause too low evaporating temperatures with the action of safety devices which would stop the unit.

Chilled water temperature (summer operation)

The minimum temperature allowed at the evaporator outlet is 5 °C. To work below this limit, the unit should need some structural modifications. In this case contact our company. The maximum temperature allowed at the evaporator inlet is 20 °C.

Hot water temperature (winter operation)

Once the system is on temperature, water temperature at the condenser inlet does not have to be less than 25 °C: lower values could cause incorrect working operation of the compressor and compressor failure may occur. The maximum water temperature at the condenser outlet does not have to exceed 50 °C.

Ambient air temperature

The units are designed and manufactured to operate, in cooling, with ambient air temperature included in range of 20 to 43 °C. If a fan speed control is installed then the minimum ambient air temperature is -15°C. In winter operation (heat pump cycle) from -5°C to 20°C.

CORRECTION TABLES Different Fouling factors

Fouling factor	0,00005	0,0001	0,0002
CCCP	1	0,98	0,94
IPCF	1	0,98	0,95

CCCP = Cooling capacity correction factor.

IPCF =

Input power correction factor.

CORRECTION TABLES Operation with glycol

Water temp.	Glycol	WFCF	PDCF
7	10%	1,012	1,125
	20%	1,048	1,32
	35%	1,109	1,62
3	10%	0,87	0,85
	20%	0,875	0,92
	35%	0,925	1,13
-2	10%	0,71	0,64
	20%	0,73	0,85
	35%	0,77	1,05
-5	10%	---	---
	20%	0,60	0,56
	35%	0,625	0,7

WFCF = Water flow correction factor.

PDCF = Pressure drops correction factor.

The water flow rate and pressure drop correction factors are to be applied directly to the values given for operation without glycol. The water flow rate correction factor is calculated in order to maintain the same temperature difference as that which would be obtained without glycol. The pressure drop correction factor takes into account the different flow rate obtained from the application of the flow rate correction factor.

SOUND LEVELS STANDARD VERSIONS

Mod.	Octave bands (Hz)								Lw		Lp
	63	125	250	500	1K	2K	4K	8K	dB	dB(A)	dB(A)
	dB	dB	dB	dB	dB	dB	dB	dB			
1601	99.1	90.3	84.2	82.7	81.6	76.2	72.8	63.7	99.9	86	58
1901	101.1	92.3	86.2	84.7	83.6	78.2	74.8	65.7	101.9	88	60
2301	104.1	95.3	89.2	87.7	86.6	81.2	77.8	68.7	104.9	91	63
2701	104.1	95.3	89.2	87.7	86.6	81.2	77.8	68.7	104.9	91	63
3201	106.1	97.3	91.2	89.7	88.6	83.2	79.8	70.7	106.9	93	65
3202	106.1	97.3	91.2	89.7	88.6	83.2	79.8	70.7	106.9	93	65
3601	106.1	97.3	91.2	89.7	88.6	83.2	79.8	70.7	106.9	93	65
3602	106.1	97.3	91.2	89.7	88.6	83.2	79.8	70.7	106.9	93	65
4001	107.1	98.3	92.2	90.7	89.6	84.2	80.8	71.7	107.9	94	66
4502	107.1	98.3	92.2	90.7	89.6	84.2	80.8	71.7	107.9	94	66
5202	107.1	98.3	92.2	90.7	89.6	84.2	80.8	71.7	107.9	94	66
6402	110.1	101.3	95.2	93.7	92.6	87.2	83.8	74.7	110.9	97	69
7202	111.1	102.3	96.2	94.7	93.6	88.2	84.8	75.7	111.9	98	70
8202	112.1	103.3	97.2	95.7	94.6	89.2	85.8	76.7	112.9	99	71
9002	113.1	104.3	98.2	96.7	95.6	90.2	86.8	77.7	113.9	100	72

SOUND LEVELS LOW NOISE VERSIONS

Mod.	Octave bands (Hz)								Lw		Lp
	63	125	250	500	1K	2K	4K	8K	Db	dB(A)	dB(A)
	dB	dB	dB	dB	dB	dB	dB	dB			
1601/LS	96.1	87.3	81.2	79.7	78.6	73.2	69.8	60.7	96.9	83	55
1901/LS	98.1	89.3	83.2	81.7	80.6	75.2	71.8	62.7	98.9	85	57
2301/LS	101.1	92.3	86.2	84.7	83.6	78.2	74.8	65.7	101.9	88	60
2701/LS	101.1	92.3	86.2	84.7	83.6	78.2	74.8	65.7	101.9	88	60
3201/LS	103.1	94.3	88.2	86.7	85.6	80.2	76.8	67.7	103.9	90	62
3202/LS	103.1	94.3	88.2	86.7	85.6	80.2	76.8	67.7	103.9	90	62
3601/LS	103.1	94.3	88.2	86.7	85.6	80.2	76.8	67.7	103.9	90	62
3602/LS	103.1	94.3	88.2	86.7	85.6	80.2	76.8	67.7	103.9	90	62
4001/LS	104.1	95.3	89.2	87.7	86.6	81.2	77.8	68.7	104.9	91	63
4502/LS	104.1	95.3	89.2	87.7	86.6	81.2	77.8	68.7	104.9	91	63
5202/LS	104.1	95.3	89.2	87.7	86.6	81.2	77.8	68.7	104.9	91	63
6402/LS	107.1	98.3	92.2	90.7	89.6	84.2	80.8	71.7	107.9	94	66
7202/LS	108.1	99.3	93.2	91.7	90.6	85.2	81.8	72.7	108.9	95	67
8202/LS	109.1	100.3	94.2	92.7	91.6	86.2	82.8	73.7	109.9	96	68
9002/LS	110.1	101.3	95.2	93.7	92.6	87.2	83.8	74.7	110.9	97	69

Lw: Sound power level according to ISO 3746.

Lp: Sound pressure level measured at 10 mt from the unit in free field conditions direction factor Q=2 according to ISO 3746.

SAFETY DEVICE SETTING

Device		Capacity Steps		Capacity steps		Reset Type
		2		4		
		Set-point	Differential	Set point	Differential	
Control thermostat (summer)	°C	10	2	9	3	...
Control thermostat (winter)	°C	42	2	43	3	...
Anti-freeze thermostat	°C	4	6	4	6	MANUAL
Electric heater thermostat	°C	4	6	4	6	MANUAL
High pressure switch	Bar	28	7	28	7	MANUAL
Low pressure switch	Bar	0,7	1	0,7	1	MANUAL
Water safety valve (Optional)	Bar	6	...	6

ELECTRIC DATA

Power supply	V/~/Hz	400 / 3 / 50	Control board	V/~/Hz	24 / 1 / 50
Auxiliary circuit	V/~/Hz	230 / 1 / 50	Fans power supply	V/~/Hz	400 / 3 / 50

Electric data may change for updating. It is therefore necessary to refer always to the wiring diagram inside the units.



WARNING: All this operation described in next chapters MUST BE DONE BY TRAINED PEOPLE ONLY. Before every operation of servicing on the unit, be sure that the electric supply is disconnected.

INSPECTION

When installing or servicing the unit, it is necessary to strictly follow the rules reported on this manual, to conform to all the specifications of the labels on the unit, and to take any possible precautions of the case. Not observing the rules reported on this manual can create dangerous situations. After receiving the unit, immediately check its integrity. The unit left the factory in perfect condition; any eventual damage must be questioned to the carrier and recorded on the Delivery Note before it is signed. HIDROS must be informed, within 8 days, of the extent of the damage. The Customer should prepare a written statement of any severe damage.

LIFTING AND HANDLING

When unloading the unit, it is highly recommended to avoid any sudden move in order to protect refrigerant circuit, copper tubes or any other unit component. Units can be lifted by using a forklift or, in alternative, using belts, being sure that the method of lifting does not damage the lateral panels and the cover. It is important to keep the unit horizontal at all time to avoid damages to the internal components.

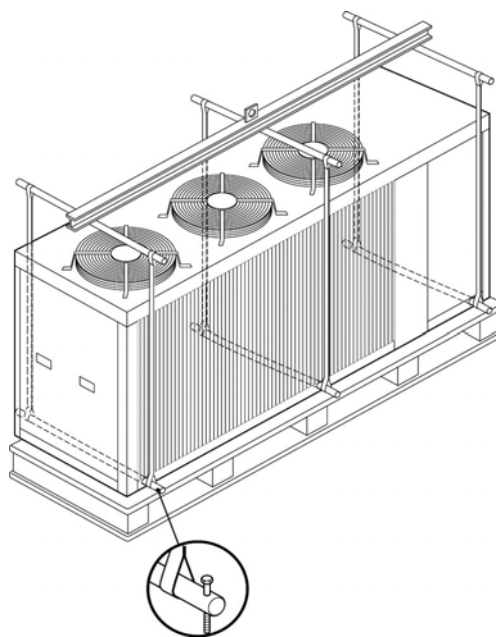

LOCATION AND MINIMUM TECHNICAL CLEARANCES

LVK units are designed for external installation: any cover over the unit and location near trees (even if they partially cover the unit) must be avoided in order to prevent air by-pass. It is advisable to create a proper basement, with a size similar to unit foot-print. Unit vibration level is very low: it is advisable however, to fit a rigid rubber band between basement and unit base-frame. If it is the case, it is possible to install anti-vibration mounts (spring or rubber), to keep vibrations at a very low level. Absolute care must be taken to ensure adequate air volume to the condenser. Re-circulation of discharge air must be avoided; not observing this point will result in poor performance or activation of safety controls. For these reasons it is necessary to observe the following clearances:

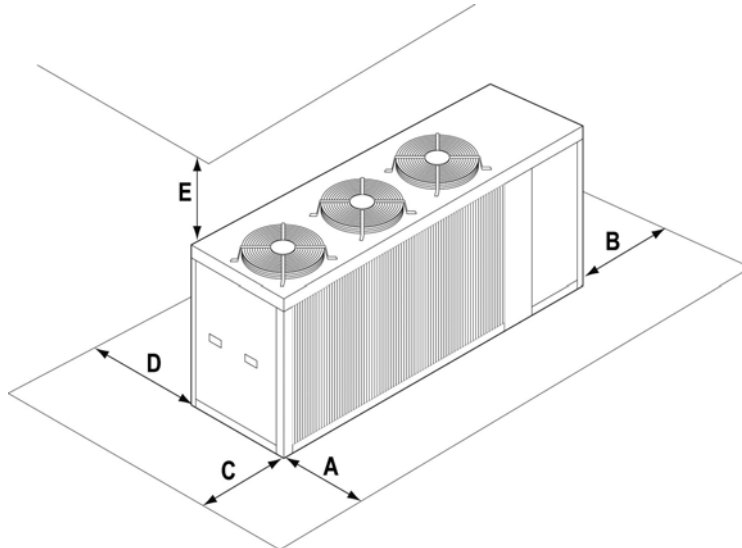

Mod.	A	B	C	D	E
1601	1500	1000	1000	1000	4000
1901-2301-2701	2000	1000	1000	1000	4000

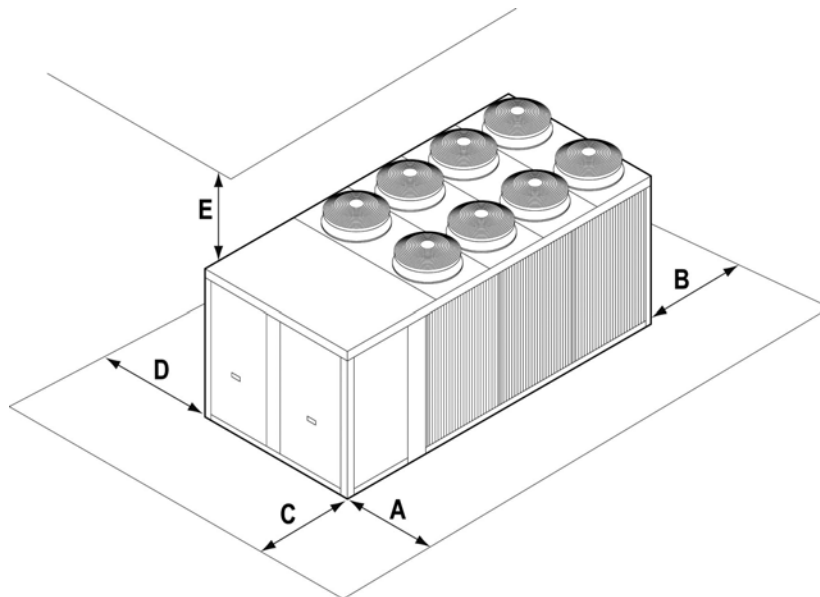

Mod.	A	B	C	D	E
3201-3202-3601-3602-4001-4502	2000	1000	2000	2000	5000
5202 – 6402	2000	1000	2000	2000	5000
7202 – 8202	2000	1000	2000	2000	5000
9002	20000	1000	2000	2000	5000



WARNING: The equipment should be installed so that maintenance and/or repair services be possible. The warranty does not cover costs due to lifting apparatus and platforms or other lifting systems required by the warranty interventions.



WARNING: All the maintenance operation must be done by TRAINED PEOPLE only.



WARNING: Before any service operation on the unit, be sure that the electric supply is disconnected.



WARNING: Inside the unit some moving components are present. Be very careful when operating in their surroundings even if the electric supply is disconnected.



WARNING: The top shell and discharge line of compressor are usually at high temperature level. Be very careful when operating in their surroundings.

WARNING: Aluminium coil fins are very sharp and can cause serious wounds. Be very careful when operating in their surroundings



WARNING: After servicing operation close the unit with cover panels, fixing them with locking screws

HYDRAULIC CONNECTIONS

Unit water pipe-work must be installed in accordance with national and local regulation, pipes can be made either in steel , galvanized steel or PVC. Pipes have to be designed depending on the nominal waterflow and the hydraulic pressure drops of the system. All pipes must be insulated with closed-cell material of adequate thickness. The chiller has to be connected to the piping by using flexible joints. Piping should include:

- Temperature and pressure gauges for the ordinary maintenance or servicing operations.
- Shut-off manual valves to separate the unit from the hydraulic circuit.
- Metallic filters to be mounted on the inlet pipe with a mesh not larger than 1 mm.
- Vent valves, expansion tank with water filling, discharge valve.



WARNING: Unit water inlet must be in correspondence with the connection labelled: "USER WATER IN", otherwise the heat exchangers may freeze.

WARNING: It is compulsory to install on the USER WATER IN connection a metallic filter with a mesh not larger than 1 mm. The presence of the filter is to be considered mandatory, the warranty will no longer be valid if it is removed. The filter must be kept clean, so make sure it is clean after the unit has been installed, and then check it periodically.



WARNING: All units are factory supplied with the flow switch (it is factory installed in the "A" versions, supplied loose in the standard versions). The flow switch **MUST BE INSTALLED** on the water outlet connection (labelled USER WATER OUT); If the flow switch is altered, removed, or the water filter should not be present on the unit, the warranty will be invalidated. Please refer to the wiring diagram for flow switch electric connections.

Basic version hydraulic components

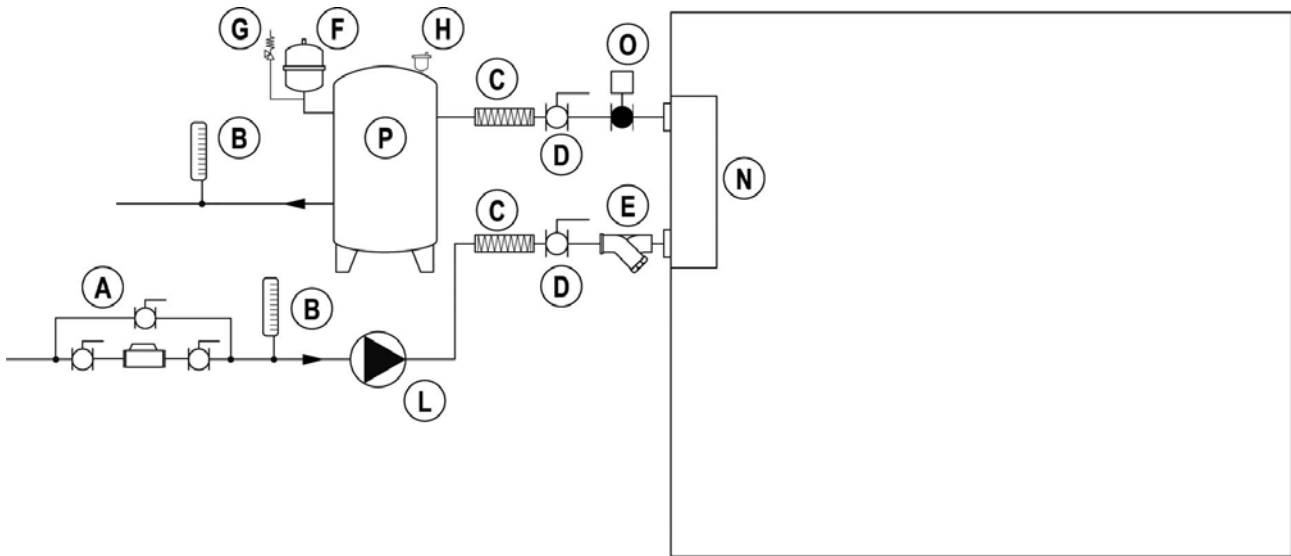

“A” version hydraulic components

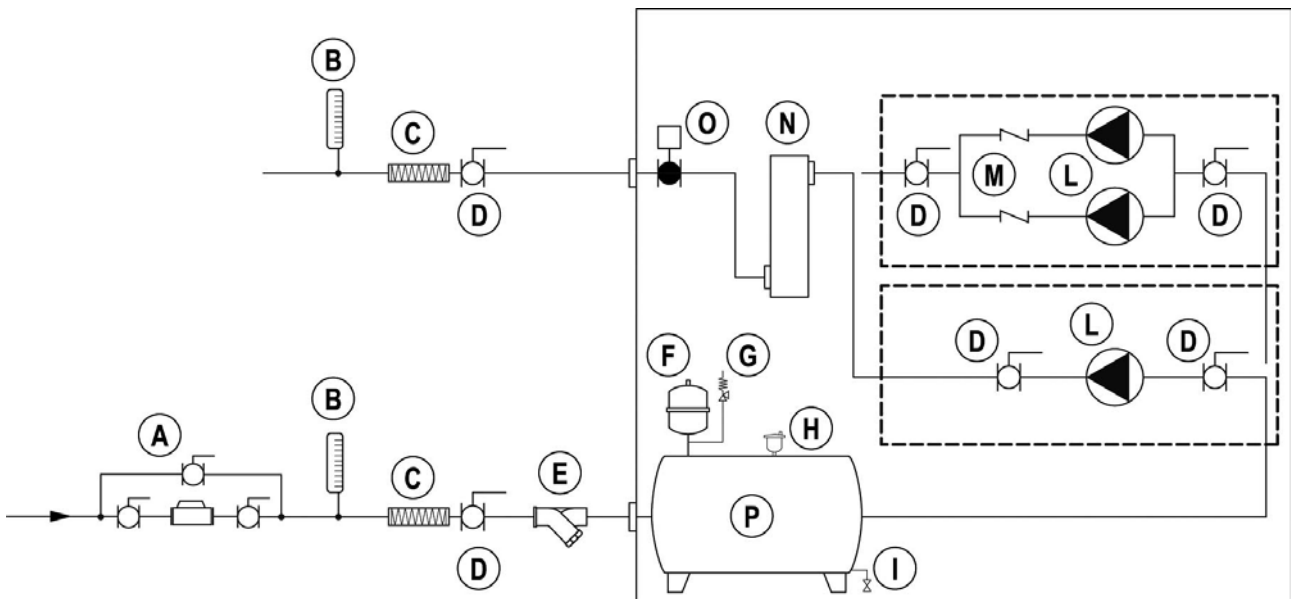

A	System filling group	H	Vent valve
B	Thermometer	I	Water tank Drainage valve
C	Flexible connection	L	Water pump
D	Ball shut-off valve	M	One way valve
E	Water strainer	N	Evaporator
F	Expansion vessel	O	Flow switch
G	Safety valve	P	Water tank

LVK / FC FREE COOLING VERSION

The free cooling versions operates in 3 different working modes. The free-cooling coil is installed in series with the water chiller evaporator; the 3 way valve controls the water flow through the coil. When the ambient temperature is lower than the return water temperature the microprocessor allows the water flow to pass through the free-cooling coil first, then through the evaporator.

Cooling mode (Summer operation) Ambient temperature is higher than the return water temperature. In this case, the ambient conditions are not suitable to allow Free Cooling operation; the 3 way valve is closed and the water flow passes to the evaporator where it is cooled. The compressors, fans, and the water pump are activated; the unit operates like a normal liquid cooler.

Free cooling mode (Winter operation) Ambient temperature is much lower than the return water temperature. In this case, the ambient conditions are suitable to allow Free Cooling operation; the 3 way valve opens and the water flow passes into the free cooling coil where the ambient conditions are sufficient to give the total required load. In this case the pump and the fans are in operation, while the compressors are stopped. In this case, the free cooling system works in substitution of the water chiller.

Cooling mode + Free cooling (Mid-season operation) Ambient temperature is lower than the return water temperature. In this case, the ambient conditions are suitable to allow Free Cooling operation; the 3 way valve opens and water flow passes into the free cooling coil although the ambient conditions are not sufficiently low to give the total required load. The microprocessor control then, activates the compressors (Pump and fans are already in operation) to satisfy the required load. In this case the free cooling system works in integration of the water chiller. In such conditions also the head pressure control device is activated.

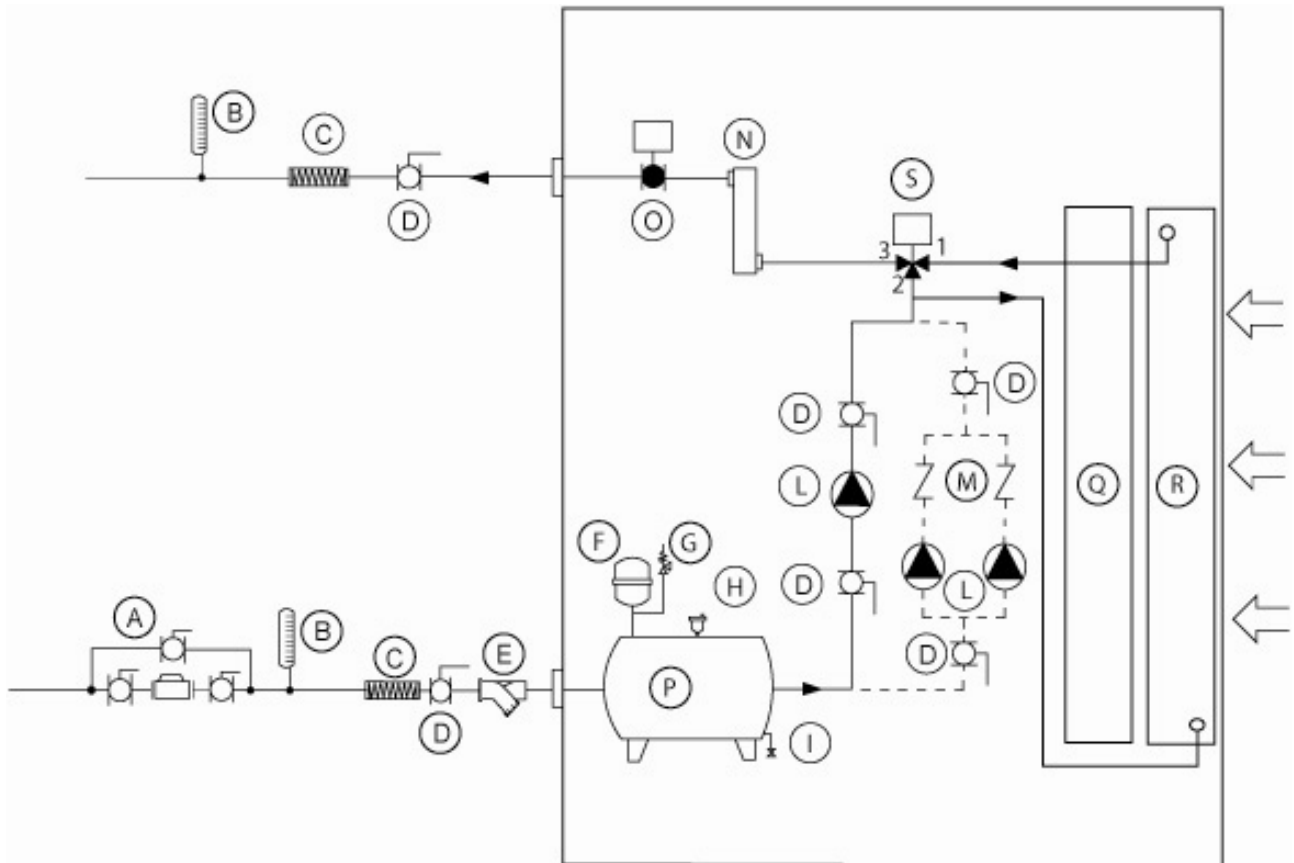

A	System filling group	L	Water pump
B	Thermometer	M	One way valve
C	Flexible connection	N	Evaporator
D	Ball shut-off valve	O	Flow switch
E	Water strainer	P	Water tank
F	Expansion vessel	Q	Condensing coil
G	Safety valve	R	Free cooling coil
H	Vent valve	S	3 Way valve
I	Water tank Drainage valve		

REMOTE CONTROL PANEL



WARNING: The remote control panel is connected to the water chiller by 2 wires of 2,5 mm² section. Power supply cables must be separated by remote control wires. Maximum distance 50 metres.



WARNING: The remote control panel can not be installed in area in with strong vibrations, corrosive gases, excess of dirtiness or high humidity level. Leave free the area near the cooling openings.

Dimensions: 100 x 64 mm

FAN SPEED CONTROL (optional)

If unit operation below 20 °C (in cooling mode) is required, fan speed control must be present in the unit. This device will allow unit operation under low ambient temperature, by reducing condenser air flow and obtaining in this way permissible operating parameters. This device can be used as well to reduce unit sound level emission when ambient temperature is decreasing (i.e. during night time).



WARNING: Fan speed control is factory pre-set. The values must never be modified

ELECTRICAL CONNECTIONS

It must be verified that electric supply is corresponding to the unit electric nominal data (tension, phases, frequency) reported on the label in the front panel of the unit. Power connections must be made in accordance to the wiring diagram enclosed with the unit and in accordance to the norms in force. Power cable and line protection must be sized according to the specification reported on the form of the wiring diagram enclosed with the unit.



WARNING: The line voltage fluctuations can not be more than $\pm 5\%$ of the nominal value, while the voltage unbalance between one phase and another can not exceed 2%. If those tolerances should not be respected, please contact our Company.



WARNING: Electric supply must be in the limits shown: in the opposite case warranty will terminate immediately. Before every operation on the electric section, be sure that the electric supply is disconnected.

WARNING: The Flow switch must be connected following the indication reported in the wiring diagram. Never bridge the flow switch connections in the terminal board. Guarantee will be invalidated if flow switch connections are altered or not properly made.

START UP

Before start-up

- Check that all power cables are properly connected and all terminals are hardly fixed.
- The voltage at the phase R S T is the one shown in the unit labels.
- Check that there is not any refrigerant leakage.
- Check that crankcase heaters are powered correctly.
- Check that all water connections are properly installed and all indications on unit labels are observed.
- The system must be bleed off in order to eliminate any air.
- Before proceeding to start up check that all the panels are re-located in the proper position and locked with fastening screws.



WARNING: Crankcase heaters must be powered at least 12 hours before start up by closing the main switch (heaters are automatically supplied when main switch is closed). The crankcase heaters are working properly if after some minutes the compressor crankcase temperature is about 10-15°C higher than ambient temperature

Start up

Please refer to the microprocessor manual enclosed with the unit.

If the unit should not start:

- Check that the control thermostat is set to the correct value.



WARNING: Do not modify internal wiring of the unit otherwise warranty will terminate immediately.

WARNING: for heat pump versions, the summer/winter operation must be selected at the beginning of the related season. Frequent change over of the seasonal operation mode must be avoided in order to prevent severe damage to compressors.

Controls during unit operation

- Check the fans rotation. If the rotation is incorrect, disconnect the main switch and change over any two phases of the incoming main supply to reverse motor rotation:
- Check that water temperature at evaporator inlet is near to the set point of the control thermostat.
- For "A" version units (units with pumps and storage tank) if the motor driven pump should be noisy, slowly close discharge shut-off valve until normal working conditions are restored. This trouble may occur when system pressure drop is quite different from pump available pressure.

Refrigerant charge checking

- After few hours the unit is working, check that sight glass shows a green colour core: if the core is yellow moisture would be present in the circuit. In this case it is necessary circuit dehydration to be carried out by qualified people only. Check that at the sight glass there is no continuous vapour bubbles presence. In this case additional refrigerant charge could be required. It is however allowed the presence of few vapour bubbles.
- Few minutes after the start up, working on summer operating mode (cooling), check that condensing temperature, is approximately 15 °C higher than condenser inlet air temperature. Check moreover that evaporation temperature is about 5 °C lower than the evaporator outlet temperature.
- Check that refrigerant superheat on the evaporator is about 5-7 °C
- Check if refrigerant sub-cooling on the condenser is about 5-7 °C.

Unit switch OFF

Please refer to the microprocessor manual enclosed with the unit.



WARNING: Never switch off the unit (for temporary stop), by opening the main switch: this component should be used only to disconnect the unit from power supply when the current is not passing through, i.e. when the unit is in OFF mode. Moreover, with no supply to crankcase heater, at the unit start up, compressor could be seriously damaged.

MAINTENANCE AND PERIODIC CHECKS



WARNING: All operations described in this chapter **MUST BE DONE BY TRAINED PEOPLE ONLY**. Before every operation of servicing on the unit, be sure that the electric supply is disconnected. The top shell and discharge line of compressor are usually at high temperature level. Be very careful when operating in their surroundings. Aluminium coil fins are very sharp and can cause serious wounds. Be very careful when operating in their surroundings. After servicing operation close the unit with cover panels, fixing them with locking screws.

It is a good rule to carry on periodic checks in order to verify the correct operation of the unit.

- Check that safety and control devices work correctly as previously described (monthly).
- Check all the terminals on the electric board and on the compressor are properly fixed. Periodic cleaning of the sliding terminals of the contactors should be done.
- Verify refrigerant charge checking sight glass (monthly).
- Check there is no oil leakage from compressor (monthly).
- Check there is no water leakage in the hydraulic system (monthly).
- If the unit is to be expected to be stopped for a long period, unit hydraulic circuit should be emptied from all the tubes and heat exchanger. This operation is compulsory if, during seasonal stop, ambient temperature is expected to go down below the freezing point of employed mixture (typical seasonal operation).
- Check flow switch proper working (monthly).
- Check compressor crankcase heater proper supply and functioning (monthly).
- Clean metallic filters on water pipings (monthly).
- Clean finned coils metallic filters with compressed air in the opposite direction of the air flow. If filters should be fully clogged clean them with a water jet (monthly).
- Check mounting of fan blades and their balancing (every 4 months).
- Check the colour of the sight glass core (green=no moisture, yellow=moisture present): if it has a yellow colour, change the refrigerant filter (every 4 months).

REFRIGERANT CIRCUIT REPAIR

In the case that refrigerant circuit should be discharged, all the refrigerant must be recovered with proper machines. The system must be charged with nitrogen, using a gas bottle with a pressure reducing valve, until 15 bar pressure is reached. Any eventual leakage must be searched with a bubble leak finder. In case bubbles appear discharge the circuit before welding with proper alloys.



WARNING: Never use oxygen instead of nitrogen: explosions may occur.

ENVIRONMENT PROTECTION

According to European norms dealing with the use of depleting stratospheric ozone substances, it is forbidden to release refrigerants fluids in the atmosphere. They must be redelivered to the seller or to proper gathering points at the end of their operating life. Refrigerant gas R407C is mentioned among controlled substances and for this reason it must be subjected to said norms. **A particular care is recommended during service operations in order to reduce as much as possible any refrigerant loss.**

UNIT OUT OF SERVICE

Once the unit is arrived at the end of its life and needs to be removed or replaced, the following operations are recommended:

- the unit refrigerant has to be recovered by trained people and sent to proper collecting centre;
- compressor lubricating oil has to be recovered and sent to proper collecting centre;
- the frame and various components, if not usable any longer, have to be dismantled and divided according to their nature; particularly copper and aluminium, which are present in conspicuous quantity in the unit. These operations allow easy material recover and recycling process, reducing environmental impact.

FAULT FINDING

Please refer to the unit microprocessor manual.

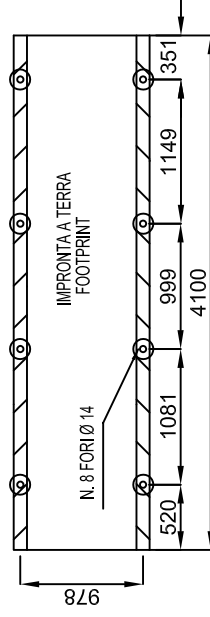
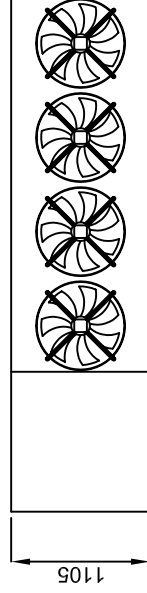
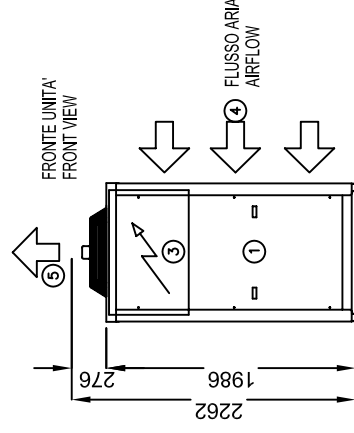
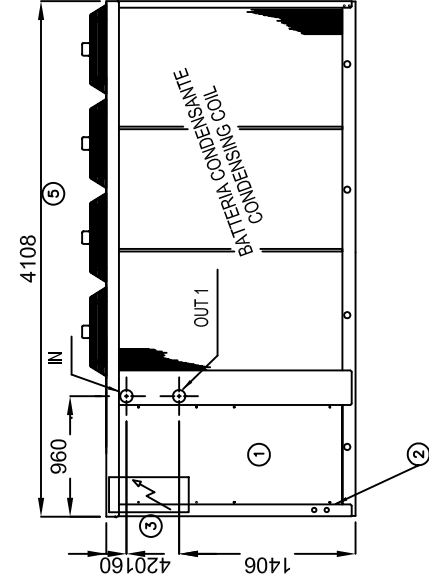
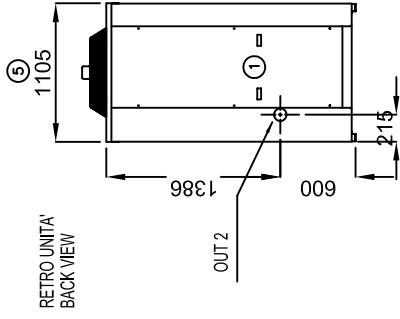

1	PANNELLI DI ISPEZIONE INSPECTION PANEL
2	INGRESSO ALIMENTAZIONE ELETTRICA POWER SUPPLY INLET
3	QUADRO ELETTRICO ELECTRICAL BOX
4	ASPIRAZIONE SUCTION
5	MANDATA AIR OUTLET
IN	INGRESSO ACQUA UTENTE USER WATER INLET R2-1/2"
OUT1	USCITA ACQUA UTENTE LVK USER WATER OUTLET LVK R2-1/2"
OUT2	USCITA ACQUA UTENTE VERSIONI LVK / A USER WATER OUTLET UNITS LVK / A R2-1/2"

Descrizione modifica/Review description

Denominazione/Denomination
SCHEMA DIMENSIONALE REFRIGERATORE LVK1601
WATER CHILLER DIMENSIONAL DRAWING LVK1601

Disegno/Drawing	Rev.	Date/Date	Foglio Sheet N. 1 di 1	Scala/Scale	Form.	Visto/Checked by
SD.1LDK.0045	A	13/09/06	1	1:50	A4	
Sost. il dis./Replace draw.			Sost. dal dis./Replaced by draw.		Dis./Draftsman	

◇ OPZIONALE/OPTIONAL
 ○ SOLO SU TAGLIE/ONLY ON SIZE

REV.

□
 ○
 ▢

Dis./Draftsman

Visto/Checked by

Descrizione modifica/Review description

Ordine-Order

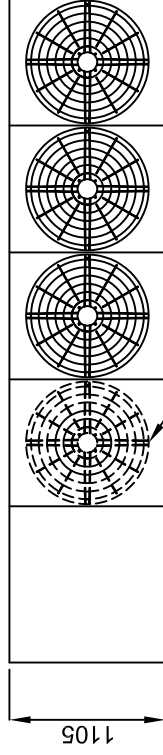
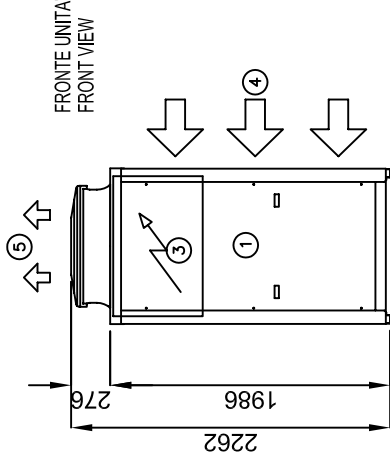
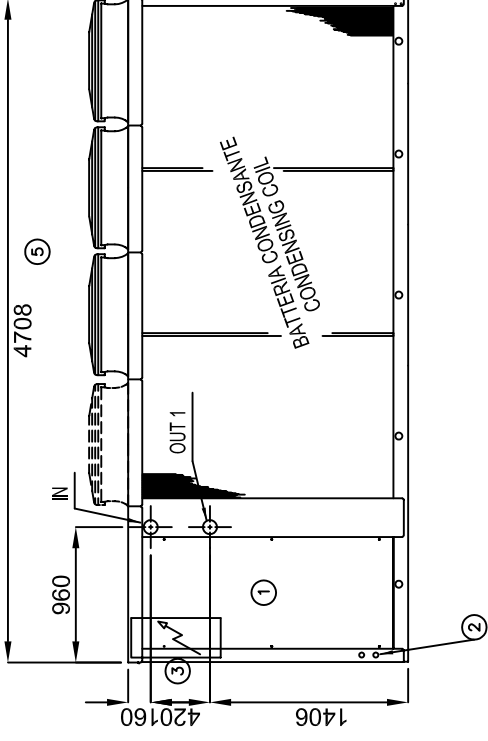
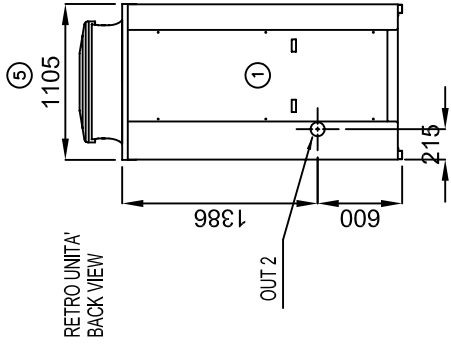

1	PANNELLI DI ISPEZIONE INSPECTION PANEL
2	INGRESSO ALIMENTAZIONE ELETTRICA POWER SUPPLY INLET
3	QUADRO ELETTRICO ELECTRICAL BOX
4	ASPIRAZIONE SUCTION
5	MANDATA AIR OUTLET
IN	INGRESSO ACQUA UTENTE USER WATER INLET R 2 1/2"
OUT1	USCITA ACQUA UTENTE LVK USER WATER OUTLET LVK R 2 1/2"
OUT2	USCITA ACQUA UTENTE VERSIONI LVK / A USER WATER OUTLET UNITS LVK / A R 2 1/2"

VENTILATORE NON PRESENTE SU LVK1901
FAN NOT INSTALLED ON LVK1901

IMPRONTA A TERRA
FOOTPRINT

N. 10 FORI Ø 14

Denominazione/Denomination
SCHEMA DIMENSIONALE REFRIGERATORE LVK 1901-2301-2701
WATER CHILLER DIMENSIONAL DRAWING LVK1901-2301-2701

Disegno/Drawing	Rev.	Date/Date	Foglio Sheet N. 1 of 1	di	Scala/Scale	Form.
SD.1LDK.0050	A	13/09/06	1	of	1:50	A4
Sost. il dis./Replace draw.			Dis./Draftsman		Visto/Checked by	
						Ordine-Order

◇ OPZIONALE/OPTIONAL
 ○ SOLO SU TAGLIE/ONLY ON SIZE

Descrizione modifica/Review description

REV.

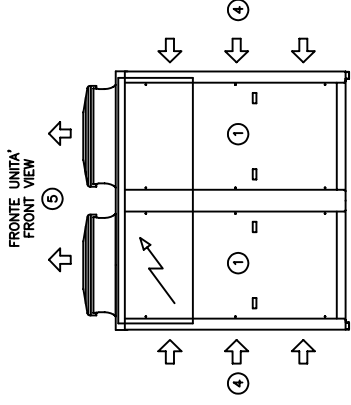
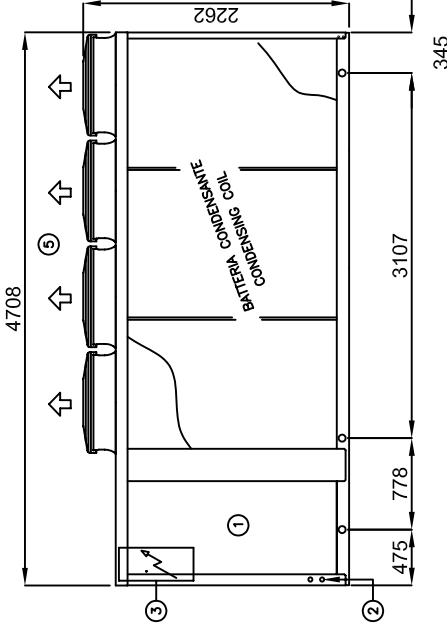
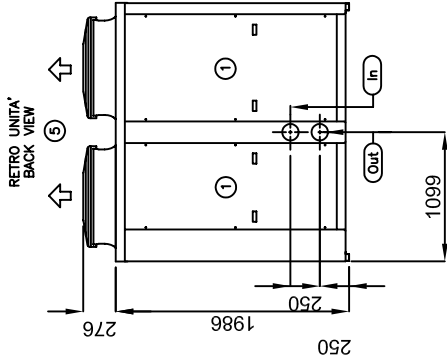

VISTA IN PIANTA
TOP VIEW

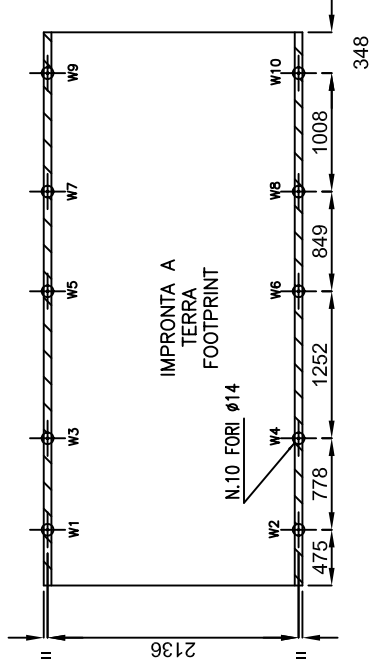
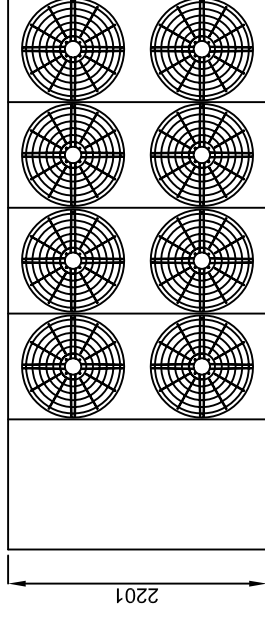

1	PANNELLI DI ISPEZIONE	
1	INSPECTION PANEL	
2	INGRESSO ALIMENTAZIONE ELETTRICA	
2	POWER SUPPLY INLET	
3	QUADRO ELTRICO	
3	ELECTRICAL BOX	
4	ASPIRAZIONE	
4	SUCTION	
5	MANDATA	
5	AIR OUTLET	
IN	INGRESSO ACQUA UTENTE	R-5"
IN	USER WATER INLET	R-5"
OUT	USCITA ACQUA UTENTE	R-5"
OUT	USER WATER OUTLET	R-5"

Descrizione modifica/Review description

- ◇ OPZIONALE/OPTIONAL
- SOLO SU TAGLIE/ONLY ON SIZE

Denominazione/Denomination

SCHEMA DIMENSIONALE LVK 3201-3202-3601-4001
DIMENSIONAL DRAWING LVK 3201-3202-3601-4001

Disegno/Drawing	Rev.	Date/Date	Foglio Sheet N. 1 di 1	Scala/Scale	Form.	
SD.1LDK.0060	A	13/09/06		1:50	A4	
Sost. il dis./Replace draw.			Sost. dal dis./Replaced by draw.		Dis./Draftsman	
					Visto/Checked by	
					Ordine-Order	

REV.

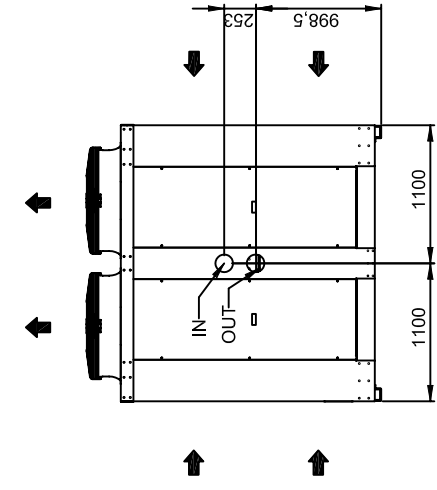

RETRO UNITA'
BACK VIEW

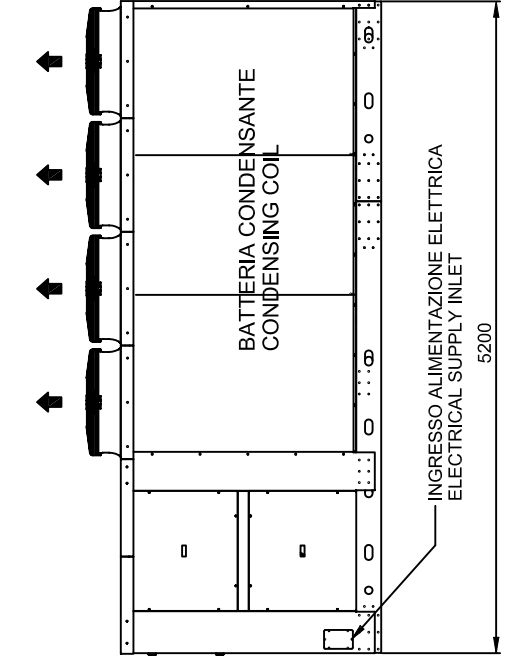

FRONTE UNITA'
FRONT VIEW

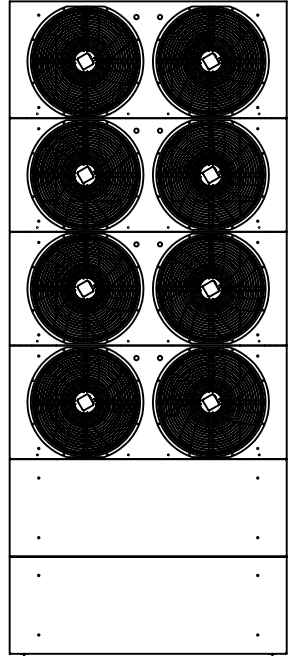
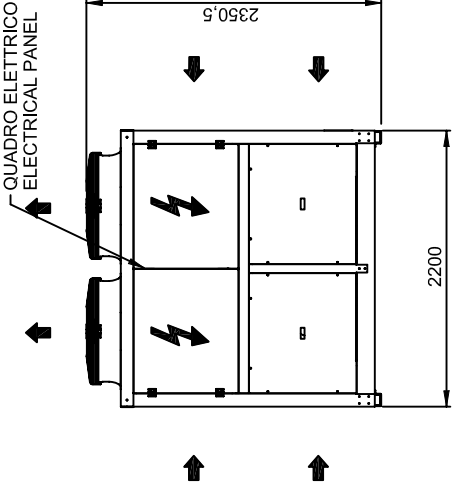

MODELLO / MODEL	INGRESSO ACQUA UTENTE USER WATER INLET	USCITA ACQUA UTENTE USER WATER OUTLET
LVK 3602	5"	5"
LVK 4502	5"	5"

Qual'ora si tratti di un'opera di ingegneria, il presente disegno è proprietà intellettuale del gruppo di progettazione e non può essere copiato, ristampato o distribuito senza permesso scritto dalla Ing. SBAVATURA.

SCHEMA DIMENSIONALE LVK 3602-4502 MULTIVALE PANTAMBATO SPA	DIMENSIONI: A3 DATA: 12/01/07 AUTORE: LVK/ozz	S (mm) = 610 H (mm) = 9 F (mm) = 1 b (mm) = 4 a (°) = 45°	QUOTE DI VERIFICA SUP. IN VISTA SUP. NON IN VISTA LATO IN VISTA
--	---	---	--

Foglio 1 di 1
 Compressivo
 Data: 12/01/07
 Autore: LVK/ozz

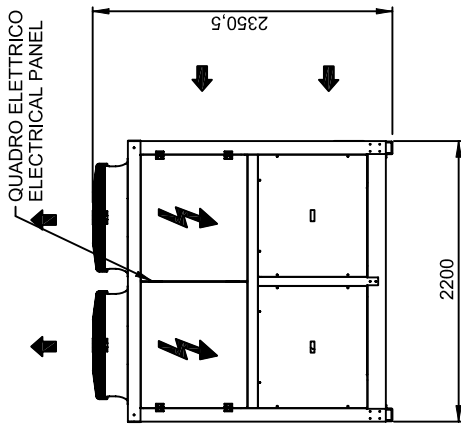

FRONTE UNITA'
FRONT VIEW

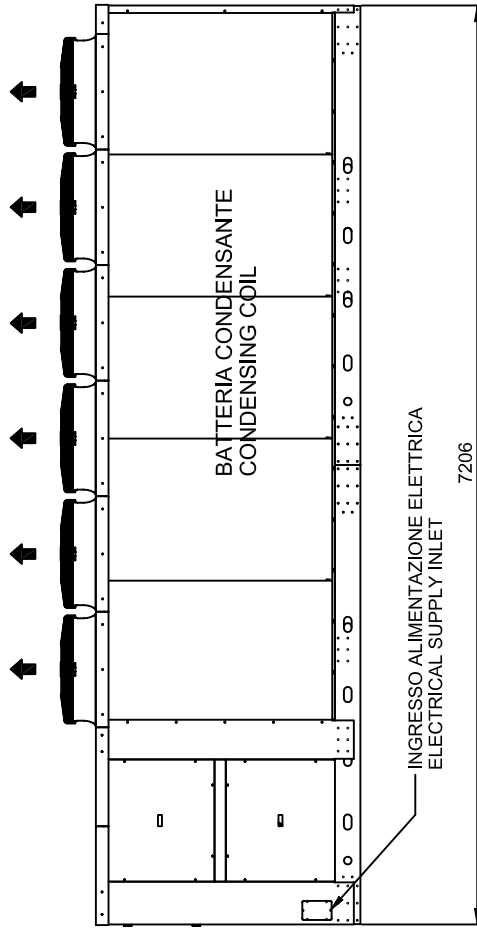

RETRO UNITA'
BACK VIEW

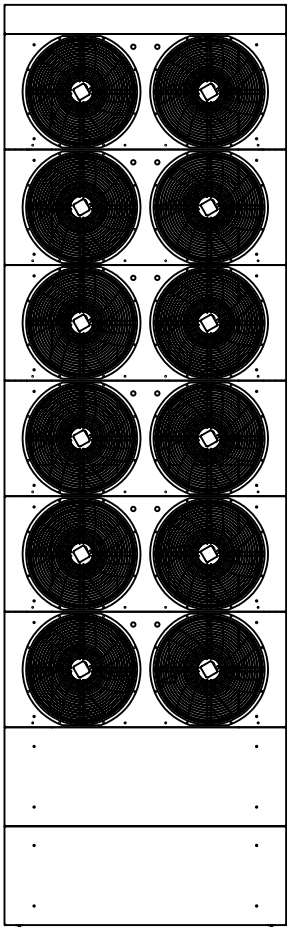

MODELLO / MODEL	INGRESSO ACQUA UTENTE / USER WATER INLET	USCITA ACQUA UTENTE / USER WATER OUTLET
LVK 6402	6"	6"
LVK 7202	6"	6"

Dimensioni mm		Dimensioni pollici	
Altezza mm A3	2011	7-12 1/8	800
Profondità mm B3	2011	7-12 1/8	800
Spessore mm C3	2011	7-12 1/8	800
Spessore mm D3	2011	7-12 1/8	800
Spessore mm E3	2011	7-12 1/8	800
Spessore mm F3	2011	7-12 1/8	800
Spessore mm G3	2011	7-12 1/8	800
Spessore mm H3	2011	7-12 1/8	800
Spessore mm I3	2011	7-12 1/8	800
Spessore mm J3	2011	7-12 1/8	800
Spessore mm K3	2011	7-12 1/8	800
Spessore mm L3	2011	7-12 1/8	800
Spessore mm M3	2011	7-12 1/8	800
Spessore mm N3	2011	7-12 1/8	800
Spessore mm O3	2011	7-12 1/8	800
Spessore mm P3	2011	7-12 1/8	800
Spessore mm Q3	2011	7-12 1/8	800
Spessore mm R3	2011	7-12 1/8	800
Spessore mm S3	2011	7-12 1/8	800
Spessore mm T3	2011	7-12 1/8	800
Spessore mm U3	2011	7-12 1/8	800
Spessore mm V3	2011	7-12 1/8	800
Spessore mm W3	2011	7-12 1/8	800
Spessore mm X3	2011	7-12 1/8	800
Spessore mm Y3	2011	7-12 1/8	800
Spessore mm Z3	2011	7-12 1/8	800

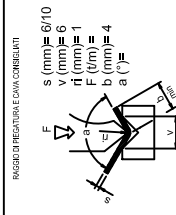

DESCRIZIONE	SCHEMA DIMENSIONALE	LVK 6405-7202
MODELLO	LVK 6405-7202	
DESCRIZIONE	SCHEMA DIMENSIONALE	
PRODOTTORE	FRONTIERE S.P.A.	
MODELLO	LVK 6405-7202	
DESCRIZIONE	SCHEMA DIMENSIONALE	
PRODOTTORE	FRONTIERE S.P.A.	
MODELLO	LVK 6405-7202	
DESCRIZIONE	SCHEMA DIMENSIONALE	
PRODOTTORE	FRONTIERE S.P.A.	

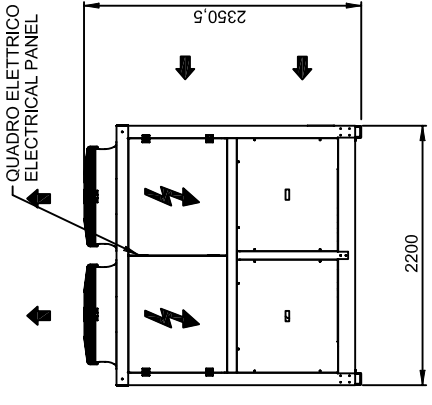

FRONTE UNITA'
FRONT VIEW

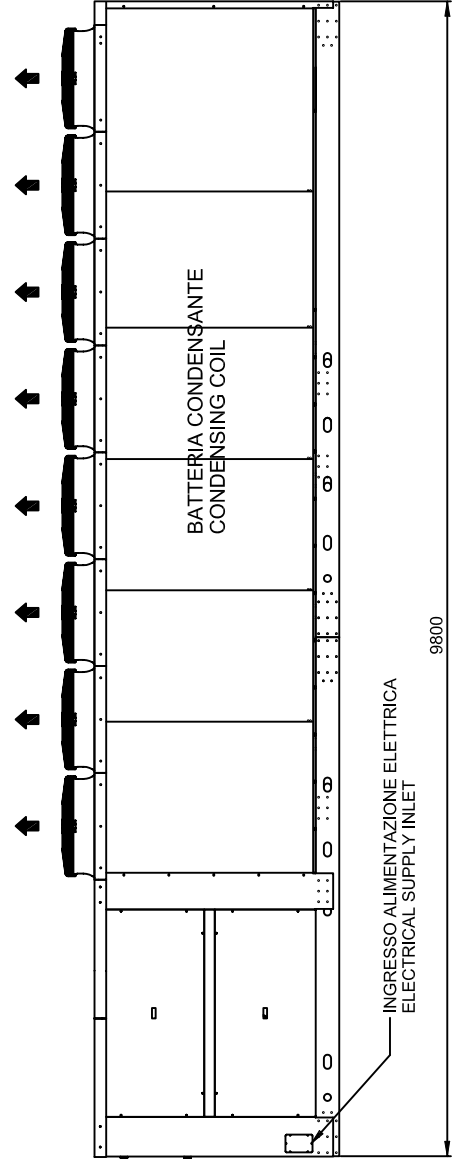

9600

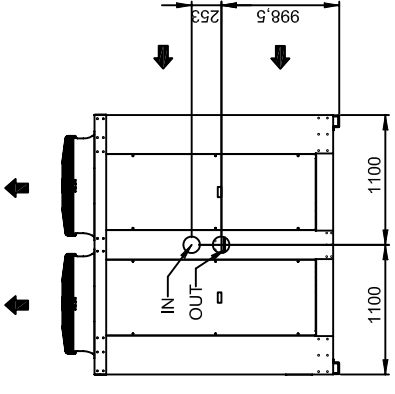

RETRO UNITA'
BACK VIEW

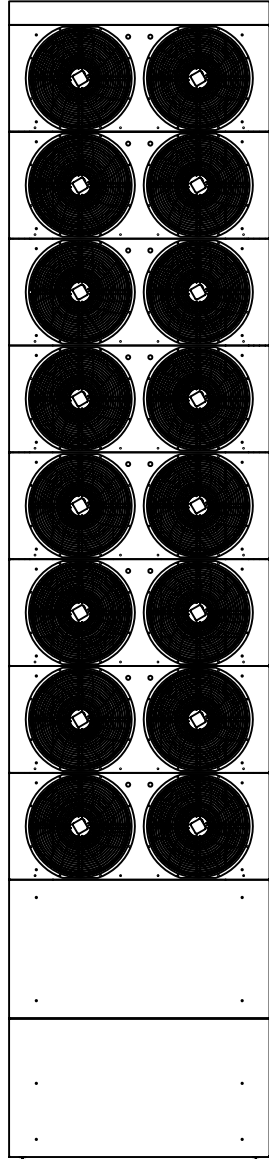

MODELLO / MODEL	LVK 9202	INGRESSO ACQUA UTENTE USER WATER INLET	6"	USCITA ACQUA UTENTE USER WATER OUTLET	6"
-----------------	----------	---	----	--	----

Quota senza indicazione di tolleranza: grado di precisione medio UNI 27881		Dimensioni in mm		Tolleranze	
Dimensione	0.10	0.20	0.50	1.00	1.50
0.10	±0.03	0.20	±0.05	0.50	±0.10
1.00	±0.10	1.50	±0.15	2.00	±0.20
2.00	±0.20	3.00	±0.30	4.00	±0.40
5.00	±0.50	10.00	±1.00	15.00	±1.50
20.00	±2.00	50.00	±5.00	100.00	±10.00
Dimensioni in mm (dalla parte superiore)	Dimensioni in pollici				
1"	25.4	2"	50.8	3"	76.2
4"	101.6	6"	152.4	8"	203.2
10"	254.0	12"	304.8	14"	354.3

PRODOTTO IN ITALIA

SCHEMA DIMENSIONALE LVK 9202

FOGLIO 1 di 1 Completo

NON INVENTO SUP.

DATA: 12/01/07

REVISIONI:

DESCRIZIONE: 1LVK.9202

QUANTITA':

UNITA':

PRODOTTORE:

PRODOTTORE:

PRODOTTORE:



Ferrol Spa
Via Ritonda 78/A
37047 San Bonifacio (Vr)
Tel.+39.045.6139411
Fax.+39.045.6100233
www.Ferrol.it

Technical data shown in this booklet are not binding.
Ferrol Spa shall have the right to introduce at any time whatever modifications necessary to the improvement of the product.